

Zeta Rev HP XT

42÷204 kW



General

Reversible heat pumps. Extreme operating limits. Dedicated configuration options.

Configurations

/LN: silenced unit

/DS: execution featuring a desuperheater

Strengths

- ▶ High outlet water temperature: up to 65°C
- ▶ Operation down to ambient -20°C with outlet water at +55°C
- ▶ Efficient energy performance: COP up to 3,5
- ▶ Intelligent management of defrost cycles: Anti-Ice Circuit
- ▶ BlueThink advanced control with integrated web server. Multilogic function and Blueeye® supervision system. (options)
- ▶ Flowzer: inverter driven pumps (options)



Zeta Rev HP XT

Product description	3
Description of accessories	6
Refrigerant circuit accessories	6
Fan accessories	7
Hydraulic circuit accessories	8
Electrical accessories	16
Network accessories	19
Other accessories	22
Technical specifications	23
Ecodesign	25
Electrical specifications	29
Hydraulic modules	30
Pump data	31
User-side exchanger flow rate fields	32
Operating limits	33
Noise levels	34
Configurations that are not possible	35
Installation advice	36
Water characteristics	36
Glycol mixtures	36
Minimum water content in the system	37
Installation site	38
Installations that require the use of treated coils	39
Aeraulic head losses and options available for the ventilating section	40
Dimensional diagrams	42



Zeta Rev HP XT

PRODUCT DESCRIPTION

Reversible heat pumps. Extreme operating limits. Dedicated configuration options.

BODY

The structure of the unit is made of galvanized sheet-iron coated with polyester powder in RAL 5017/7035 at 180°C, which makes it highly resistant to weather conditions.

The structure is a load-bearing frame, with removable panneling lined with sound absorbing expanded polyurethane matting.

All screws and bolts are stainless steel.

REFRIGERANT

The unit is charged with refrigerant R410A, with GWP=2088 (value at 100 years).

COMPRESSORS

The compressors are hermetic orbiting spiral scroll compressors with vapour injection, connected in tandem. They are provided with thermal overload protection by internal Klixon® or external Kriwan© module (depending on the model), integrated control for the maximum discharge temperature, and with oil equalization line. All the compressors are fitted as standard with crankcase heater.

The compressors are enclosed in a dedicated technical compartment, which can be accessed by removing the panneling to allow maintenance operations to be carried out even with units running.

SOURCE-SIDE HEAT EXCHANGER

The exchangers are made with finned pack coils with copper tubes and aluminium fins.

The coils have an increased fin pitch to reduce frost formation and to facilitate the outflow of condensed water during defrosting.

An Anti-Ice Circuit is installed at the base of each coil: this prevents ice formation in the lower part of the coil and therefore allows the unit to operate even with extremely harsh temperatures and with high humidity levels.

The Anti-Ice Circuit is shut off by a solenoid valve managed by the controller of the unit to ensure this is running only when the coils work as evaporator and only when the external air temperature makes it really necessary.

Options are available for installations in environments with especially aggressive atmospheres, in areas along the coast or in highly industrialized zones. Ref. section: "Description of options".

FANS

The fans are axial fans, directly coupled to a 6-pole electric motor, with integrated thermal overload protection (Klixon®) and IP 54 protection rating.

The fan includes the shroud, designed to optimize its efficiency and reduce noise emission to a minimum, and the safety guard.

USER-SIDE HEAT EXCHANGER

The exchanger is a braze-welded stainless steel plate heat exchanger, insulated with a shroud of closed-cell insulating material.

Models with 2 refrigerant circuits are fitted with dual circuit heat exchanger and therefore with a single pair of hydraulic connections.

The exchanger is also equipped with thermostat-controlled anti-freeze heater to protect it from ice formation when the unit is not running.

REFRIGERANT CIRCUIT

The unit uses refrigerant gas R410A.

Each refrigerant circuit of the unit comprises:

- electronic expansion valve
- 4-way reversing valve
- suction separator
- fluid accumulator
- economizer
- electronic expansion valve dedicated to the economizer
- replaceable solid cartridge dehydrator filter (except for sizes 3.2, 4.2 and 5.2 where the filter is a weld-on filter)
- pressure transducers for reading high and low pressure values
- high pressure switches
- safety valves
- liquid sight glass
- 5/16" charging valves
- Anti-Ice Circuit with solenoid valve

The pipes of the circuit and the exchanger are insulated with extruded closed-cell expanded elastomer.

ELECTRICAL CONTROL PANEL

The electrical control panel is made in a painted galvanized sheet-iron box with forced ventilation and IP54 protection rating.

The electrical control panel of the basic unit comprises:

- main disconnect switch
- automatic circuit breakers for compressors with fixed calibration
- fuses for protecting the fans and auxiliary circuits
- fan contactors
- phase-cutting fan speed adjuster
- thermal magnetic circuit breakers for pumps (if present)
- phase monitor
- potential-free general alarm contacts
- single potential free operating contacts for compressors, fans and pumps (when present)
- digital input for general ON/OFF
- summer/winter selection by digital input
- external air temperature probe
- microprocessor controller with display accessible from the outside

All the electrical cables inside the panel are numbered and the terminal board dedicated to the customer's connections is coloured orange so that it can be quickly identified in the panel.

The standard power supply of the unit is 400V/3~+N/50Hz for models from 3.2 to 8.2

The standard power supply of the unit is 400V/3~/50Hz for models from 9.4 to 18.4

CONTROL BLUETHINK

Main controller functions

The microprocessor control allows the following functions:

- water temperature control, with control of the water leaving the user-side exchanger
- freeze protection
- compressor timings
- automatic rotation of compressor starting sequence
- recording of the log of all machine inputs, outputs and states
- automatic rotation of compressor starting sequence
- recording of the alarm log
- sliding defrost management
- sliding defrost management
- digital input for general ON/OFF
- summer/winter selection by digital input
- RS485 serial port with Modbus protocol
- Ethernet serial port with Modbus protocol and integrated web server preloaded web page

For further details on available functions and on displayed information, you can refer to the specific documentation of the control.

By default, the serial connections present as standard are enabled only for reading from BMS. Enabling of writing from BMS is to be requested when ordering.

Main functions of the webserver

As standard, the Bluethink controller integrates a webserver with a preloaded web page that is accessed via password.

The web page allows the following functions to be carried out (some of these are available only for users with advanced level rights):

- display of the main information on the unit, such as serial n°, size, type of refrigerant
- display of the general status of the machine: water inlet and outlet temperatures, external air temperature, operating mode, evaporating and condensing pressures, suction and discharge temperatures
- display of the status of compressors, fans, pumps, electronic expansion valves
- display in real time of the graphs of the main quantities
- display of the graphs of logged quantities
- display of alarm log
- display of the status of all the I/Os of the controller
- management of users on several levels
- remote ON/OFF
- remote set point change
- remote time band change
- remote summer winter mode selection

Human-Machine Interface

The control has a graphic display that allows the following information to be displayed:

- water inlet and outlet temperature
- set temperature and differential set points
- description of alarms
- hour meter of operation and number of start-ups of the unit, the compressors and the pumps (if present)
- high and low pressure values, and relevant condensing and evaporating temperatures
- external air temperature
- superheating at compressor suction.

Management of defrost cycles

For defrost management, the control of the unit uses a sliding intervention threshold, depending on the pressures inside the unit and the external air temperature. By putting together all this information, the control can identify the presence of ice on the coil and activates the defrosting sequence only when necessary, so as to maximize the energy efficiency of the unit.

Sliding management of the defrost threshold ensures that, as the absolute humidity of outdoor air decreases, the frequency of the defrost cycles gradually decreases because they are carried out only when the ice formed on the coil actually penalizes performance.

The defrost cycle is fully automatic and is carried out using a patented defrost system (patent n° 1335232): during the initial stage, a defrost is carried out by cycle reversal with fans stopped. When the frost on the coil has melted sufficiently, reverse ventilation is activated, that is, with air flow in the opposite direction to that of normal operation, so as to facilitate the ejection of condensed water and detached ice. When the coil is clean, ventilation is reversed again and the unit resumes operation in heat pump mode.

The combination of the sliding intervention threshold and the patented defrost system allows the number and duration of defrost cycles to be optimized and reduced to the minimum.

CONTROLS AND SAFETY DEVICES

All the units are fitted with the following control and safety components:

- user-side water temperature probe
- antifreeze probe on the user side heat exchanger
- high pressure switch (with manual reset)
- low pressure safety device (with manual reset managed by the controller)
- compressor overtemperature protection
- fan overtemperature protection
- water differential pressure switch

TESTING

All the units are factory-tested and supplied complete with oil and refrigerant.

PACKAGING

The unit is made and shipped on a wooden pallet that allows the unit to be handled using a forklift truck.

The unit is wrapped in a protective transparent polyethylene stretch film.

OPTIONS

/LN: silenced unit

In the unit with /LN option, the technical compartment that houses the compressors is fully soundproofed with sound absorbing material and soundproofing material.

/DS: unit with desuperheater

/DS units comprise (for each refrigerant circuit) an exchanger for condensation heat recovery of up to 20% (depending on size, version and operating conditions), placed in series with the condensing coil. The exchanger is a braze-welded plate heat exchanger. For multi-circuit units, the exchangers are to be manifolded outside the unit (by the customer).

The desuperheater can be used during operation in cooling mode. However, it can also be used in heating mode on condition that the following measures are taken:

- a valve (either 2- or 3-way) must be installed on the desuperheater water circuit;
- the valve must be monitored using a temperature control system;
- the valve must be operated to regulate the temperature of the input water into the desuperheater = IWTds.

First, enter the unit heating setpoint, which corresponds to the temperature of water delivered to the heating unit=LWTu_Heating. Then set the condition below:

- $IWTds > LWTu_Heating + 10 [K]$

The valve, the control systems and their installation, setup operations, etc. are the responsibility of the client. If heat recovery is not required during operation in heat pump mode, or where the above requirements are not met, the water circuit of the desuperheater must be shut off. Desuperheater operation in heat pump mode reduces the heating capacity transferred from the unit to the user's hydronic circuit. When a desuperheater is fitted, irrespective of it running in either cooling or heating mode, the max. temperature of water delivered to the heating unit (LWTu_Heating) is reduced, as described in the section "Operating limits".

HYDRAULIC MODULES

All units can be fitted with hydraulic module in various configurations:

- /1P: hydraulic module with one pump
- /2P: hydraulic module with two pumps
- /1PS: hydraulic module with one pump and buffer tank
- /2PS: hydraulic module with two pumps and buffer tank

All the above-mentioned modules have pumps with standard discharge head.

The following are also available:

- modules /1PM, /2PM, /1PMS and /2PMS that have pumps with increased available discharge head

Hydraulic modules with one pump have:

- one pump
- a gate valve on the delivery side of the pump
- an expansion vessel

Hydraulic modules with two pumps have:

- two pumps
- a check valve on the delivery side of each pump
- a gate valve on the outlet of the delivery manifold
- an expansion vessel

In the version with 2 pumps, these are always with one on standby while the other is working. Switching over between the pumps is automatic and is done by time (to balance the hours of operation of each one) or in the event of failure.

Hydraulic modules with tank also have:

- a gate valve at the inlet of the pump or the suction manifold
- a tank with drain valve and air valve

Refer to the table of configurations that are not possible to check for availability of specific set-ups.

DESCRIPTION OF ACCESSORIES

Refrigerant circuit accessories

BC Capacitive backup battery for electronic expansion valve

When the compressors stop, the controller always closes the electronic expansion valve to prevent dangerous refrigerant migration. The presence of the backup battery ensures that the electronic valve is kept in closed position even when there is no power supply

This accessory uses a condenser, and not an ordinary battery, as energy storage: this allows it to be unaffected by the memory effect of normal batteries and eliminates its need for maintenance.

DVS Double safety valve

With this accessory, instead of each individual safety valve per circuit, there is a "candelabrum" with two safety valves and a diverter valve for choosing the valve in operation. This allows the safety valves to be replaced without having to drain the machine and without having to stop it.

MAFR Pressure gauges

The operating pressures of each circuit of the unit can be displayed on the control by accessing the relevant screens. Also, the machine can be fitted with pressure gauges (two for each circuit) installed in a clearly visible position. These allow reading in real time of the working pressures of the refrigerant gas on the low pressure side and on the high pressure side of each refrigerant circuit.

RPP Refrigerant leak detector with automatic pump down

With this accessory, a refrigerant leak detector is placed inside each compressor compartment. Detection of a refrigerant leak is managed by the control through a specific alarm and display of a specific icon on the display of the control. For all the circuits of the unit, the alarm also starts the machine stopping procedure with pump down, confining all the refrigerant in the coils.

The accessory includes the capacitive backup battery.

RPR Refrigerant leak detector

With this accessory, a refrigerant leak detector is placed inside each compressor compartment. Detection of a refrigerant leak is managed by the controller through a specific alarm and display of a specific icon on the display of the controller. This alarm stops the unit.

RUB Compressor suction and delivery valves

The valves situated on the delivery side and on the suction side of the compressors allow the compressor to be isolated from the rest of the refrigerant circuit, so making the maintenance operations quicker and less invasive

Fan accessories

VEC EC fans

With this accessory, EC fans, with electronically commutated brushless motor, are used for the ventilating section. These guarantee very high efficiency levels for all working conditions and allow a 15% saving on the power absorbed by each fan working at full capacity.

Also, through a 0-10V analogue signal sent to each fan, the microprocessor carries out condensation/evaporation control by continuous adjustment of the air flow rate as the external air temperature changes, with a further reduction in electrical absorption and noise emission.

For further details, see the dedicated chapter: "Aeraulic load losses and options available for the fan section".

VEM Oversize EC fans

The increased EC fans allow to obtain the same benefits as EC fans and in addition allow to have a residual useful head of about 100Pa.

For further details, see the dedicated chapter: "Aeraulic load losses and options available for the fan section".

RECP Pressure recuperator

Normally, the air ejected by the fan has a high speed and this manifests itself as kinetic energy that is dissipated into the environment.

The pressure recuperator is a passive element situated on the ejection duct of each individual fan designed to allow better conversion of kinetic energy into static pressure, which manifests itself as a higher pressure generated by the fan.

This higher pressure can have at least two possible applications:

- For the same fan speed, the pressure recuperator allows an increase of about 50Pa in the available pressure of the ventilating section to be obtained. This can be useful for overcoming the head losses that may be present in specific installations. The increase in available pressure is to be considered in addition to the increase that can already be obtained with the application of oversize EC fans
- for the same pressure differential on the air, the pressure recuperator allows the same air flow rate to be obtained with a lower number of revolutions of the fan. This automatically produces a reduction of up to 3 dB(A) in the noise emission of the unit and a reduction in the absorption of the fan, with an immediate increase in the overall efficiency of the unit.

The reduction in total sound power varies depending on the model and version of the unit as it is related to the incidence of noise generated only by the fan section on the total noise emitted by the unit.

To allow optimization of the performance of the accessory, combination with the speed adjuster or EC fans is necessary. In this last case, the higher efficiency of the EC fans (especially when operating at low speed) is added to the performance improvement generated by the pressure recuperator.

The accessory is supplied separately from the unit on one or more pallets and it must compulsorily be installed (by the customer) before the first start-up of the machine.

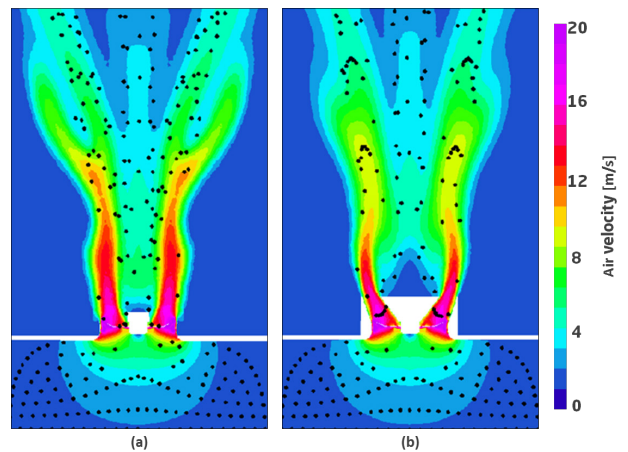
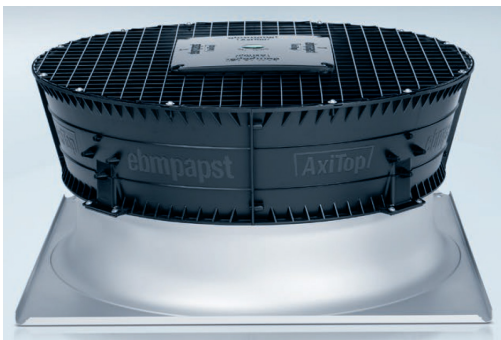

(a) fan only;

(b) fan with pressure recuperator

Hydraulic circuit accessories

CORM Connection for manual filling

This accessory allows the system filling procedure to be carried out directly from the unit: on the fan holder cover, there is a 1" filling valve and a 1/2" air valve. Near the filling valve, there is also a pressure gauge for displaying the pressure in the hydraulic circuit. This accessory can be combined only with units provided with tank.

FVP FLOWZER VP - Inverter for manual pump adjustment

The accessory consists of inserting an inverter in the machine to manually adjust the speed of the pump (or pumps) in order to calibrate the pump flow rate on the head losses of the system.

This accessory is to be combined with one of the integrated hydraulic modules that can be selected for the unit. Units equipped with integrated hydraulic module allow a certain level of available discharge head (point A) to be obtained under nominal flow rate conditions Q_d .

But the actual head loss level of the system (e.g. characteristic curve R') normally causes the pump to find a different equilibrium point (point B), with a flow rate Q_r higher than Q_d .

In this condition, in addition to having a different flow from the nominal one (therefore also a different temperature jump), there is also a greater absorption of electric power from the pump itself.

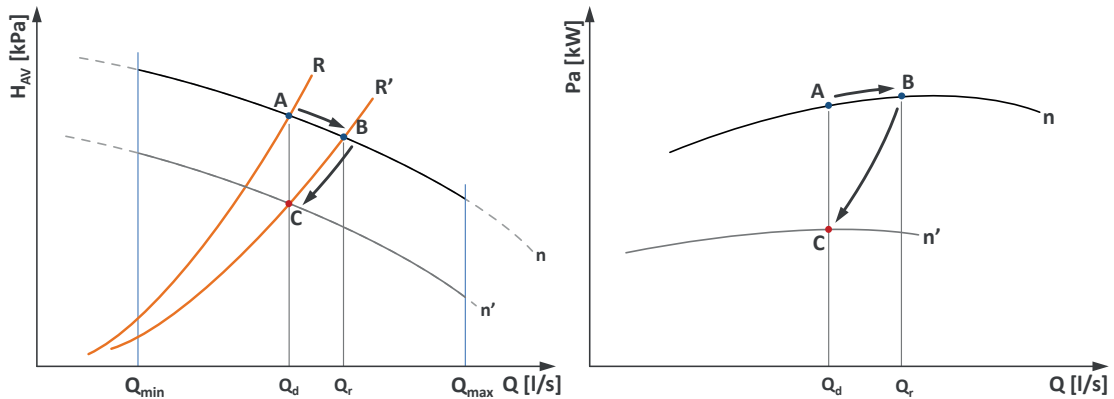

The use of the Flowzer VP allows the pump speed to be set manually (e.g. at speed n' instead of n) to obtain the design water flow rate and thermal gradient (point C). Once the adjustment procedure has been carried out, the pump will always work at a fixed flow rate.

The adoption of the VP Flowzer allows to considerably reduce the electrical power consumption of the pump with a consequent energy saving. By way of example, a reduction in the flow rate of 10% leads to a reduction in power consumption of around 27%.

FVD FLOWZER VD - Transducer for automatic adjustment

Flowzer VD requires a pressure transducer to be installed in the machine. Through this transducer, the inverter can gauge the actual pressure at the ends of the system and automatically adapt the pump speed to obtain a set available discharge head value. Flowzer VD must be combined with Flowzer VP. This accessory therefore allows a constant pressure system to be achieved.

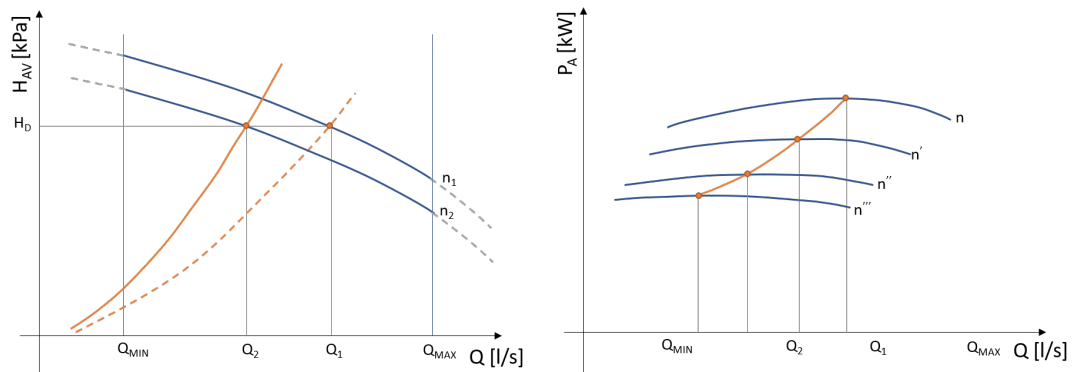

With the Flowzer VD, the customer can set, directly on the inverter, the available discharge head value H_d that the unit must maintain. As can be seen from the graph as the user request decreases, the resistant curve of the plant moves to the left, consequently the inverter reduces the speed of the pump in order to maintain the useful head necessary for the unit. With this system a significant reduction in electrical power is achieved. The customer will have to check that, in minimum flow rate conditions (that is, with the maximum number of user points closed), this is always higher than or equal to the minimum flow rate allowed by the unit.

This accessory is useful when the total head losses of the circuit are slightly variable or when they change depending on the seasons (for example, some user points are active only during summer operation and not during winter operation).

The use of this accessory also allows the pump speed to be adapted to possible fouling of the filter on the hydraulic circuit.

FVF **FLOWZER VFPP – Kit for variable flow rate primary circuit pump with bypass valve included**

Bluethink solution for a variable flow rate system, consisting solely of a user-side primary circuit.

Flowzer VFPP includes:

- a pressure transducer installed at the ends of the user-side exchanger (Δp_e)
- a dedicated control system, installed at the factory in the electrical control panel of the unit (Sc)
- a modulating bypass valve with servo-motor supplied separately with it (V_{bp}), supplied loose (installation by the customer)
- two system pressure transducers (Δp_p) supplied separately (installation by the customer)

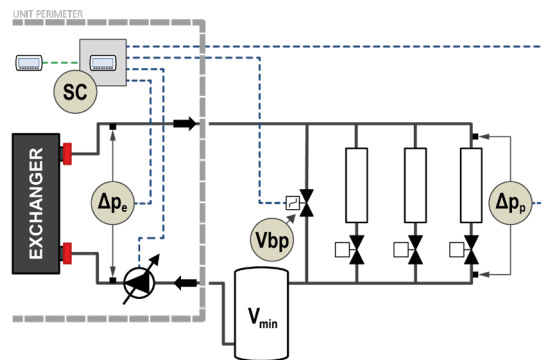

It is obligatory for the option to be combined with the Flowzer VP (inverter) and with one of the hydraulic modules that can be selected for the unit. The accessory is not compatible with Multilogic. Please contact our sales department for further details.

The unit must include the advanced Bluethink controller, just one heat exchanger on the user side and a minimum capacity step of 25% or less.

The option offers a complete default package to guarantee simple selection, purchasing and commissioning. In particular, the unit includes an additional control system, equipped with an advanced algorithm, which interacts with the main advanced Bluethink controller.

Flowzer VFPP has the advantage of:

- implementing an innovative design, which is alternative to the classic system based on fixed flow-rate primary circuit plus secondary circuit
- being ideal for new or entirely redesigned systems, especially for comfort applications
- achieving a complete variable flow system, with maximum energy saving
- simplifying the layout of the user circuit
- limiting the capex of the system
- achieving complete and reliable control of the system

The maximum energy saving is achieved thanks to:

- a hydraulic decoupler managed by the modulating bypass valve, which regulates the bypass flow rate on the lowest possible value
- an advanced algorithm to prevent hunting by the reversing valve and by the bypass valve, thereby balancing the pump speed and the bypass speed to a minimum

The capex of the system is also reduced thanks to:

- single inverter + pumping module, integrated in the unit
- small internal footprint, due to the simplified layout

The operating principle can be summarized as follows:

- Flowzer VFPP carries out constant control of the discharge head
- the system controller modulates the pump speed according to the condition detected by the system transducers Δp_p
- if the system terminals are switched off, the pump speed will decrease
- the pump speed can be reduced until it reaches the minimum allowed flow rate on the heat exchanger of the unit
- this flow rate is indirectly monitored through the losses detected by the differential pressure transducer Δp_e
- When the minimum allowed flow rate threshold is exceeded, the control system will open the bypass valve V_{bp} to recirculate the flow rate that is not required by the system, but is necessary to guarantee the minimum flow rate to the heat exchanger.

In the required minimum load condition (that is, with all system terminals switched off), the required minimum volume (V_{min}) must be concentrated in the relevant tank, to be installed between the unit and the bypass valve.

The bypass valve V_{bp} is controlled through a 0-10 V signal and must therefore be installed within 30 m of the unit.

The pressure transducers of the system Δp_p provide a 4-20 mA signal and require two 1/4" female fittings. These transducers must be installed within 200 m of the unit, near the system terminal that is affected by the highest line head losses or in any case in a position where it is possible to measure an adequate pressure value.

Further details can be found in the relevant manual.

	Bypass valve diameter
10.4	2"1/2
12.4	2"1/2
14.4	2"1/2
16.4	2"1/2
18.4	2"1/2

FVPS FLOWZER VPS – Kit for variable flow rate pump with temperature sensors

Bluethink solution for a variable flow rate system, consisting of a primary circuit plus secondary circuit.

Flowzer VPS includes:

- a differential pressure transducer, installed at the factory at the ends of the user-side heat exchanger of the unit (Δp_e)
- a dedicated control system, installed at the factory in the electrical control panel of the unit (Sc)
- two system temperature sensors (T) - supplied separately; installation by the customer

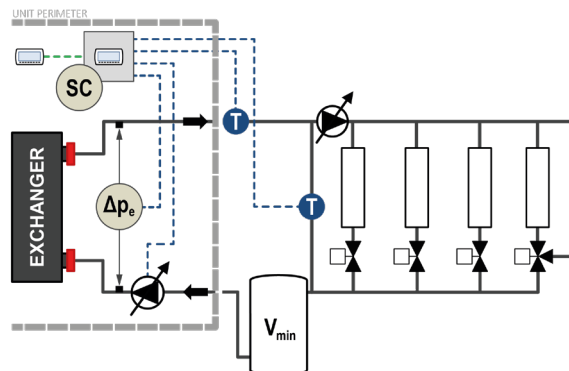

It is obligatory for the option to be combined with the Flowzer VP (inverter) and with one of the hydraulic modules that can be selected for the unit. The accessory is not compatible with Multilogic. Please contact our sales department for further details.

The unit must include the advanced Bluethink controller, just one heat exchanger on the user side and a minimum capacity step of 25% or less.

The option offers a complete default package to guarantee simple selection, purchasing and commissioning. In particular, the unit includes an additional control system, equipped with an advanced algorithm, which interacts with the main advanced Bluethink controller.

Flowzer VPS has the advantage of:

- being ideal for renovations of existing systems, especially for comfort applications
- achieving a complete variable flow system, with maximum energy saving
- implementing a flexible design, e.g. for scalable or multi-zone systems

The maximum energy saving is achieved thanks to the advanced algorithm, which prevents hunting by the inverter and balances the pump speed and the recirculation flow rate to a minimum.

With refurbishments, the system's capex is limited to the unit and its commissioning.

The dimensions of the inverter of the unit and of the pump module can be favoured by the low design discharge head of the primary circuit.

With refurbishments, the system's capex is limited to the unit and its commissioning.

The dimensions of the inverter of the unit and of the pump module can be favoured by the low design discharge head of the primary circuit.

The operating principle can be summarized as follows:

- Flowzer VPS performs intelligent control of the flow rate on the primary circuit, and balances it compared to the flow diagram of the secondary circuit
- the system controller modulates the pump speed according to the condition detected by the system sensors T
- if the system terminals are switched off, the flow rate of the secondary circuit will decrease; therefore the direction of flow is detected indirectly as temperature difference by the system sensors through the separator or the bypass pipe
- the system controller will consequently force the primary pump to reduce its speed, until it reaches the minimum allowed flow rate on the heat exchanger of the unit
- this flow rate is indirectly monitored through the losses detected by the differential pressure transducer Δp_e

In the required minimum load condition (that is, with all system terminals switched off), the necessary minimum volume (V_{min}) must be ensured by the relevant tank to be installed between the unit and the decoupler or bypass pipe.

The temperature sensors of the system T provide a 4-20 mA signal and require 1/2" female fittings.

Further details can be found in the relevant manual.

FLUS Flow switch (instead of the water differential pressure switch)

As an alternative to the differential pressure switch (standard flow sensor), it is possible to request the paddle flow switch as accessory. This detects when there is no water flow to the user-side exchanger and sends a signal to the control of the unit that will stop the compressors to prevent damage to the exchangers.

Application of this accessory is compulsory for units that use non-glycol water and work with a yearly cycle where external air temperatures are zero or below.

The flow switch is supplied loose (installation by the customer) and replaces the water differential pressure switch (standard).

IVPO Soundproofed pump compartment

With this accessory, the motor and the impeller of the pumps are enclosed in a compartment that is fully soundproofed with sound absorbing material and soundproofing material.

PFP User-side pump with Pulse function

As standard, the unit is set to keep the system-side circulation pump on all the time, even when the set point temperature is reached.

But when the unit is provided with this accessory, on reaching the set point, the controller will switch off the pump and start it again at regular intervals for a sufficient time to measure the water temperature. If the controller verifies that the water temperature is still in set point condition, it will switch off the pump again. Otherwise the controller will start the compressors again to meet the requirements of the system.

This accessory therefore allows electrical absorption due to pumping to be drastically reduced, especially in spring and autumn when the load is extremely low.

RA Antifreeze heater

These are electric heaters inserted on the user-side heat exchanger, on the pumps and in the tank (depending on the configuration of the machine) to prevent damage to the hydraulic components due to ice formation during periods when the machine is stopped.

Based on normal operating conditions and the percentage of glycol in the system, an appropriate "antifreeze alarm" temperature is set in the control. When a temperature that is 1K higher than the antifreeze alarm threshold is detected at the outlet from the exchanger, the pump (if present) and the antifreeze heaters are switched on. If the temperature of the outgoing water reaches the antifreeze alarm threshold, the compressors are stopped, keeping the heaters and the pumps active, and the general alarm contact of the machine is activated.

RINT Additional heaters (on user side)

The accessory requires an additional immersed heater to be installed directly in the tank of the hydraulic module.

The additional heater is activated only when:

- the unit is in heat pump mode
- the external air temperature is below a settable threshold (service parameter)
- the tank inlet water temperature is below a settable threshold (service parameter)

The additional heaters can have a different capacities depending on the machine model, and they can be managed with stepped control (up to 4 steps).

SID Hydraulically disconnected tank

This accessory is mandatory on units fitted with the "Automatic management of domestic hot water" accessory and a hydraulic module with tank (1PxS or 2PxS).

The tank fitted in the unit will have an inlet and outlet, flush with the machine profile, and will be disconnected from the remaining hydraulic circuit. This will allow correct enabling of the 3-way valve for domestic hot water management, thus avoiding going through the buffer tank during domestic hot water production.

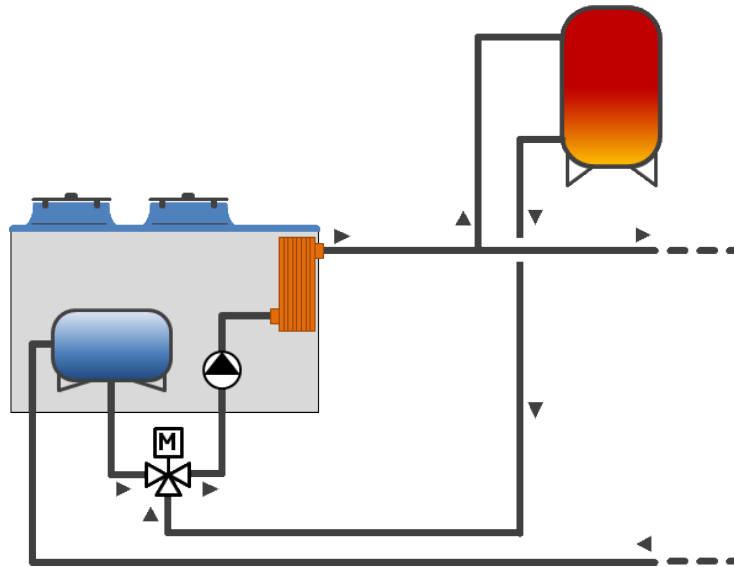

VSIW Water-side safety valve

With this accessory, a safety valve is inserted in the hydraulic circuit of the unit: when the calibration pressure is reached, the valve opens and, by discharging (to be routed by the customer), prevents the system pressure from reaching limits that are dangerous for the components present in the system. The valves have positive action, that is, performance is guaranteed even if the diaphragm deteriorates or breaks.

V3 Three-way valve for domestic hot water management

This is a three-way on-off valve, complete with servo control. The unit controller can manage two separate hydraulic circuits through this valve: one for comfort and one for domestic hot water production.

The valve and the servo control are for indoor installation and they require the ambient temperature not to drop below -10°C.

Accessory supplied loose. Installation by the customer.

HFx HYZER E VFPP function

The HYZER E VFPP function combines the Multilogic function, which is designed to manage multi-machine systems, with the FLOWZER VFPP control for variable flow systems.

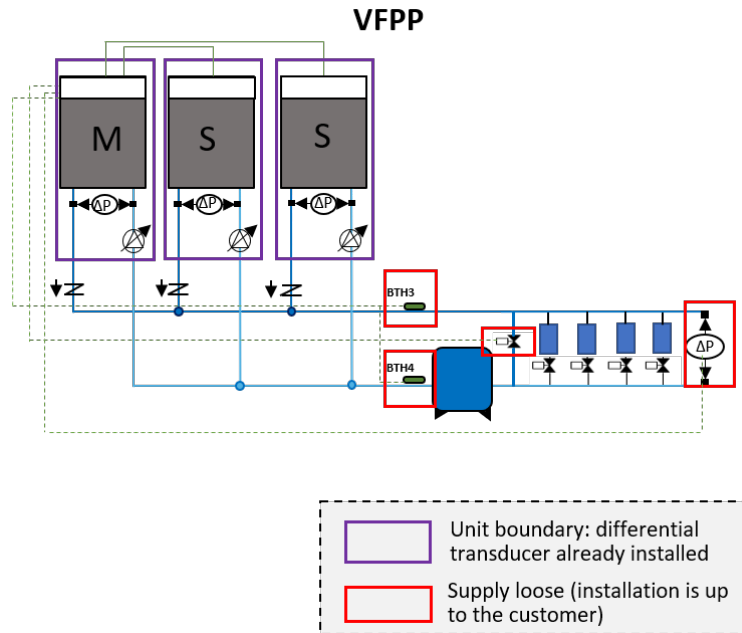

It is obligatory for the option to be combined with the Flowzer VP (inverter) and with one of the hydraulic modules that can be selected for the unit.

The unit must include the advanced Bluethink controller, just one heat exchanger on the user side and a minimum capacity step of 25% or less.

Units operate according to the Master/Slave logic that is typical of a Multilogic system. For additional details, please refer to the FMx option.

VFPP control requires the installation on the machine of a differential transducer at the ends of the user-side heat exchanger in order to keep the flow rate in the system within a specific min. value allowed.

For additional details on the FLOWZER VFPP logic, please refer to the dedicated FVF option.

The networked units may be of different types, and the same observations as for the Multilogic option apply:

- if there are both chiller units and heat pumps in the network, the Master unit must obligatorily be one of the HP units;
- if there are both free-cooling and non free-cooling units in the network, the Master unit must obligatorily be one of the free-cooling units.

The HYZER E function requested with the unit can be:

- **HF0:** HYZER E VFPP function for Slave units;
- **HF2:** HYZER E VFPP function for the Master unit in order to manage up to 2 Slave units;
- **HF6:** HYZER E VFPP function for the Master unit in order to manage up to 6 Slave units.

If you need to connect more than 6 slaves (up to 31), you can ask for a quotation from our sales department.

For the slave units, the accessory requires:

- programming of the unit as slave of a system of machines in Multilogic network

For the master units, the accessory requires:

- programming of the unit as master of a system of machines in Multilogic network
- entering of the parameters necessary for connection with the individual slave units
- installation in the electrical control panel of a network switch to allow the units to be connected in a LAN network.
- the supply of 2 temperature probes to be positioned on the delivery and return manifold for system thermoregulation (supplied with the system - installation and wiring by the customer);
- the supply of two pressure transducers (supplied with the system - installation and wiring by the customer) to be installed near the system terminal that is affected by the highest head losses in the line or in any case in a position where it is possible to measure an adequate pressure value.
- The option also includes the supply of a bypass valve controlled by a 0-10 V signal, which must be selected in function of the system capacity. Please refer to the VBx options for correct selection.

The connection between the master unit and the slave units made with a CAT cable. 5E/UTP (prepared by the customer) with RJ45 connectors. Maximum cable length 100m.
For further details, please refer to the controller manual.

VBx VFPP bypass valve for HYZER E

The option is supplied with the bypass valve, which is selected according to the system capacity.
This option must be selected with either the "HYZER E VFPP function for Master unit to manage up to 2 Slave units" or "HYZER E VFPP function for Master unit to manage up to 6 Slave units".

	System capacity range**	Quantity	Diameter	Qmax**
	kW	-	in	m ³ /h
S_A	<240	1	2 1/2"	41.3
S_B	240÷335	1	3"	57.6
S_C	335÷570	1	4"	98
S_D	570÷850	1	5"	146.2
S_E	850÷1250	1	6"	215
S_F	1250÷1700	2	2 x 5"	2 x 146.2
S_G	1700÷2500	2	2 x 6"	2 x 215

** values based on a 5 °C temperature difference between the delivery and the return temperature

HSx HYZER E VPS function

The HYZER E VPS function combines the Multilogic function, which is used to manage multi-machine systems, with the FLOWZER VPS control for variable flow systems.

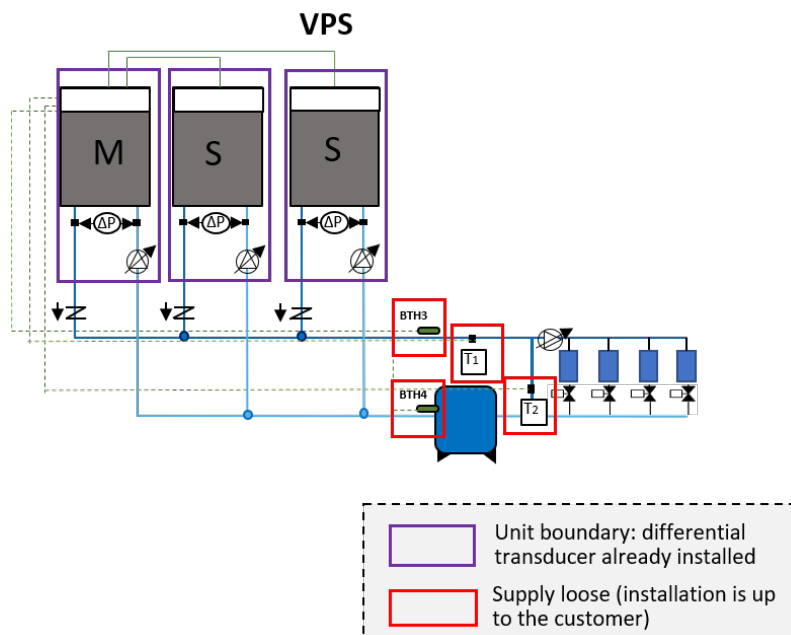

It is obligatory for the option to be combined with the Flowzer VP (inverter) and with one of the hydraulic modules that can be selected for the unit.

The unit must include the advanced Bluethink controller, just one heat exchanger on the user side and a minimum capacity step of 25% or less.

Units operate according to the Master/Slave logic that is typical of a Multilogic system. For additional details, please refer to the FMx option.

VPS control requires the installation on the machine of a differential transducer at the ends of the user-side heat exchanger in order to keep the flow rate in the system within a specific min. value allowed.

For additional details on the FLOWZER VPS logic, please refer to the dedicated FVPS option.

The networked units may be of different types, and the same observations as for the Multilogic option apply:

- if there are both chiller units and heat pumps in the network, the Master unit must obligatorily be one of the HP units;
- if there are both free-cooling and non free-cooling units in the network, the Master unit must obligatorily be one of the free-cooling units.

The HYZER E function requested with the unit can be:

- **HS0:** HYZER E VPS function for Slave units;
- **HS2:** HYZER E VPS function for the Master unit in order to manage up to 2 Slave units;
- **HS6:** HYZER E VPS function for the Master unit in order to manage up to 6 Slave units.

If you need to connect more than 6 slaves (up to 31), you can ask for a quotation from our sales department.

For the slave units, the accessory requires:

- programming of the unit as slave of a system of machines in Multilogic network

For the master units, the accessory requires:

- programming of the unit as master of a system of machines in Multilogic network
- entering of the parameters necessary for connection with the individual slave units
- installation in the electrical control panel of a network switch to allow the units to be connected in a LAN network.
- the supply of 2 temperature probes to be positioned on the delivery and return manifold for system thermoregulation (supplied with the system - installation and wiring by the customer);
- the supply of 2 temperature probes to be installed on the delivery manifold and on the bypass branch, which are typical of VPS control (supplied with the system - installation and wiring by the customer).

The connection between the master unit and the slave units made with a CAT cable. 5E/UTP (prepared by the customer) with RJ45 connectors. Maximum cable length 100m.

For further details, please refer to the controller manual.

PVX Variable flow setup for HYZER X

The dedicated HYZER X controller is designed to manage the different units, devices and components that make up a hydronic system.

Systems featuring this controller require that the PVX option be installed at the ends of the user-side heat exchanger of a differential pressure transducer so that the machine is set up for variable flow rate control.

This option is mandatory in all units making up the system.

For additional information on the product HYZER X, please refer to the specific technical catalogue.

VIX Shut-off valves for systems with external pumps for HYZER X

Systems featuring the HYZER X controller enable the selection of the shut-off valve used in systems that have an external pumping unit.

The option is always supplied separately from the unit and is for installation by the customer.

FLMX User-side flow meter for HYZER X

Systems featuring the HYZER X controller enable the selection of the flow meter option to calculate the flow rate and the performances of the units.

The option is supplied with the system for installation on the user side (installation by customer).

Electrical accessories

AS Automatic management of domestic hot water

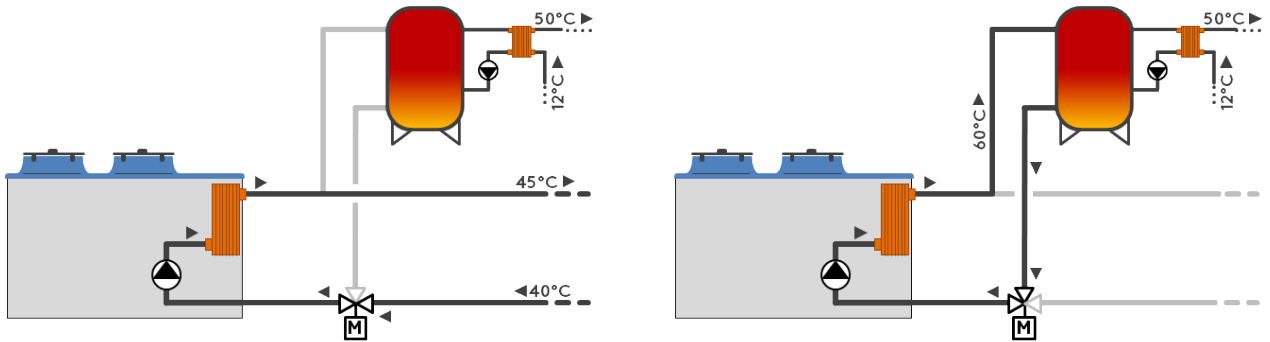

This function enables the unit to control the temperature inside a domestic hot water storage tank and to manage a 3-way valve outside the unit (available as an accessory).

The water temperature in the domestic hot water tank is controlled through a dedicated probe situated in the tank.

Normally, the heat pump operates on the system to meet the comfort requirements of the building, but when the water temperature in the domestic hot water tank falls below a set threshold, the controller switches to domestic hot water production.

If the unit is operating as heat pump for heating, the 3-way valve will be switched and the set point changed. On the other hand, if the unit is producing chilled water for air conditioning, the controller switches the unit to heat pump mode, gives it the set point for domestic hot water and turns the 3-way valve to the appropriate position. Once the temperature in the domestic hot water tank has reached the set value, the unit automatically returns to producing water for the heating or air conditioning system.

When there is a defrost request, the 3-way valve is always forced to position itself on the system, whatever operating mode it may be in.

Domestic hot water production is always given priority.

With this accessory there are two digital inputs in the electrical control panel for respectively deactivating domestic hot water production and the production of water for the heating/air conditioning system.

When the unit is working in "domestic hot water only" mode, the pump is normally off and is switched on only for the time required to meet the demand for domestic hot water production.

When this accessory is fitted, the machine must have control of pump operation. This means that either the unit is equipped with one of the hydronic modules available in the catalogue (therefore with at least one pump installed on it) or the relay for external pump management must be requested as accessory.

The probe to be fitted in the domestic hot water tank is supplied with the unit with a 5m long cable. The probe is used to measure the water temperature in the hottest part of the tank, so it must be positioned in a specially prepared pocket and secured using heat conducting paste. Installation by the customer.

CSP Set point compensation depending on external air temperature

For units fitted with this accessory, the set point of the unit is set so that it can vary between two values, a maximum and a minimum, depending on the external air temperature. The compensation ramp and the maximum and minimum values of the set point can be changed by the user.

Unless otherwise specified in the order, the controller will be set to implement a positive compensation logic according to the temperatures shown in the following diagrams:

Unless otherwise specified in the order, the controller will be set to implement a positive compensation logic according to the temperatures shown in the following diagrams:

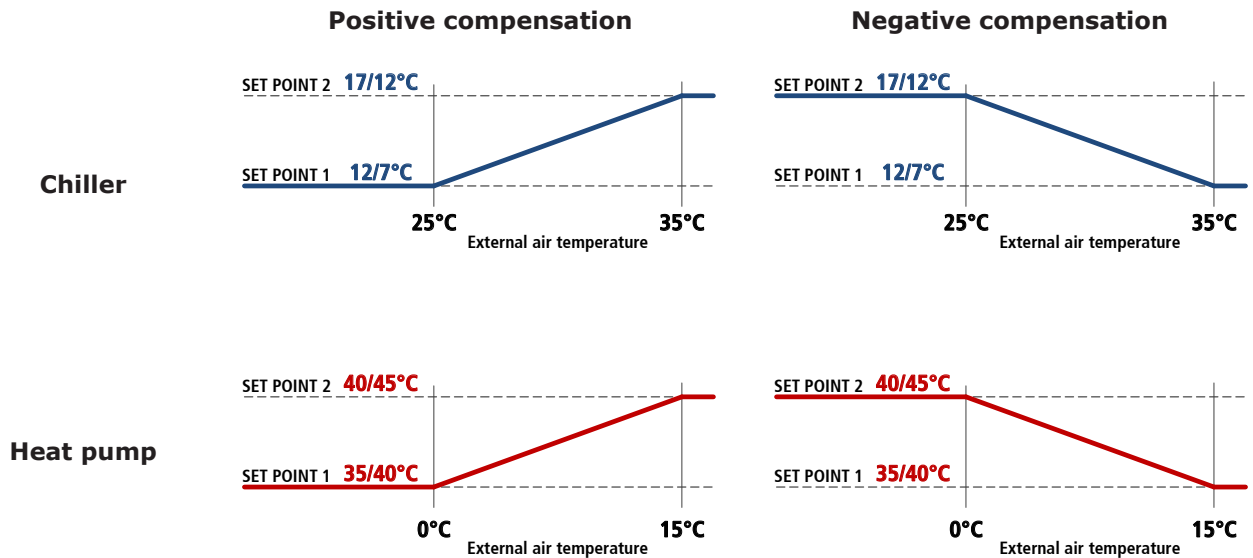

CSU Enabling for integration heater on user side

The accessory enables management of a heat source outside the unit which is supplementary to the user circuit.

The necessary OK signals for controlling a maximum of four capacity steps are included in the electrical control panel. Activation of the steps takes place depending on the distance from the set heat pump set point.

CSS Enabling for integration heater on tap water side

The accessory enables management of a heat source outside the unit which is supplementary to the domestic hot water circuit.

IACV Automatic circuit breakers

With this accessory, automatic circuit breakers are installed instead of fuses for the protection of auxiliary loads. Also, the same accessory uses automatic circuit breakers with adjustable thermal overload protection to protect the compressors.

LIID Limitation of the current absorbed by digital input

When this accessory is requested, a digital input is prepared in the terminal board to activate the forced capacity reduction of the unit to a set fixed level.

This accessory is useful when there is a need to necessarily limit the power absorbed by the unit as regards particular conditions.

We point out that, in some conditions (for example, during defrosting, oil return cycles or hourly compressor rotation procedures), the controller could force the unit to operate at full capacity for limited periods of time.

RE1P Relay for management of 1 external pump

This accessory can be requested for units without pumps and allows a pump outside the machine to be controlled.

RE2P Relay for management of 2 external pumps

This accessory can be requested for units without pumps and allows two pumps outside the machine to be controlled with a running/stand-by logic by implementing a rotation on the hours of operation.

RIF Power factor correction to $\cos\phi \geq 0.95$

With this accessory, an electrical control panel, containing power factor correction capacitors to make the $\cos\phi$ of the unit greater than or equal to 0.95, is supplied with the unit. The capacitors should be connected (by the customer) to the electrical control panel of the unit in the specially prepared terminal board.

Besides reducing the absorbed reactive power, the use of this accessory also allows the maximum absorbed current to be lowered.

RMMT Maximum and minimum voltage relay

This accessory constantly monitors the voltage value and the unit's power supply phase sequence. If the supply voltage does not fall within the set parameters or there is a phase reversal, an alarm is generated that stops the machine to prevent damage to its main parts

SETD Double set point from digital input

The accessory allows you to preset two different operating set points and manage the change from one to the other through a digital signal.

The set point temperatures must be specified when ordering. For optimization of the unit, reference will be made to the lower set point in chiller mode and the higher set point in heat pump mode.

Unless otherwise specified in the order, the controller will be set at the factory with the following temperatures:

- in chiller mode, set point 1 to 7°C and set point 2 to 12°C
- in heat pump mode (only for HP units) set point 1 to 45°C and set point 2 to 40°C

If the difference between set point 1 and set point 2 is greater than 5K, it is compulsory to ask for the accessory "Electronic expansion valve".

SETV Variable set point with remote signal

The accessory allows the set point to be varied continuously between two preset values, a maximum and a minimum, depending on an external signal that can be of the 0-1V, 0-10V or 4-20mA type.

The set point temperatures and the type of signal to use for the adjustment must be specified when ordering. For optimization of the unit, reference will be made to the lower set point in chiller mode and the higher set point in heat pump mode.

Unless otherwise specified in the order, the controller will be set at the factory with 0-10V analogue input and with the following temperatures:

- in chiller mode, 0V will correspond to a set point of 7°C and 10V will correspond to a set point of 12°C
- in heat pump mode (only for HP units), 0V will correspond to a set point of 45°C and 10V will correspond to a set point of 40°C

If the difference between the minimum set point and the maximum set point is greater than 5K, it is compulsory to ask for the accessory "Electronic expansion valve".

SOFT Electronic soft-starter

The scroll compressors have DOL (Direct On Line) starting and therefore the maximum inrush current IMIC will be 4/5 times its nominal current Inom.

If the unit is equipped with the electronic soft-starter accessory, the starting of each compressor is done with an acceleration ramp that allows the effective value (rms value) of the inrush current of the individual compressor to be lowered.

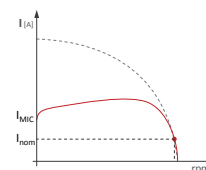
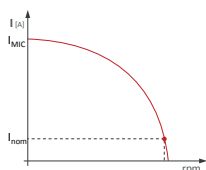

Current trend without accessory Electronic soft-starter

Current trend with accessory Electronic soft-starter

If the unit is equipped with accessory "Power factor correction to $\cos\phi \geq 0.95$ ", this last will be electro-mechanically connected only at the end of the acceleration ramp of the soft-starter.

SQE Heater for electrical control panel

Electric heaters are positioned inside the electrical control panel and these prevent the formation of ice or condensation inside it.

TERM Remote-controlled user terminal panel

This accessory allows the terminal normally situated on the machine to be replicated on a support situated at a distance. It is particularly suitable when the unit is placed in an area that is not easily accessible.

The accessory is supplied loose and is to be installed by the customer at a maximum distance of 120m from the unit. We advise using a cable of the following type: "TECO O.R. FE 2x2xAWG24 SN/ST/PUR".

For this accessory, there is a dedicated serial port.

Network accessories

BEET Blueye® via Ethernet

Blueye® is a supervision platform that enables remote monitoring of one or more units in the same system interconnected through a network with Modbus protocol.

This accessory features the Blueeye device, as already installed and wired in the unit.

The critical variables to be monitored over time are identified for each connected device. These variables are sampled and saved to the cloud so that they are accessible at all times through a web portal or a mobile APP (available for Android and iOS).

The following options can be selected for connection to the internet:

- a LAN (Ethernet) connection - available in the system;
- a connection to a mobile network - at least 3G. The data SIM card is not included.

Three different types of contracts can be signed.

Blueye® Cloud Basic:

- to monitor a max. of 20 variables in total over max. 5 units/peripherals;
- to set a min. sampling frequency of 60 seconds.

Blueye® Cloud Advanced:

- to monitor a max. of 200 variables in total over max. 10 units/peripherals;
- to set a min. sampling frequency of 5 seconds.

Blueye® Connect:

- To monitor up to 10 units/peripherals.

Subscribing to any of the **Blueye® Cloud** enables:

- viewing the history of the monitored variables, in the form of both numerical values and graphs;
- downloading the history of variables in CSV format;
- the creation of automatic reports;
- setting notifications (via APP or mail) with settable thresholds for each variable;
- switching the unit ON/OFF remotely;;
- changing the set point remotely;
- selection of SUMMER/WINTER mode remotely (for reversible units only).

The subscription to the **Blueye® Connect** service offers the advantages below:

- a safe connection (tunnelling) between the user and the remote unit through the Blueye® portal;
- full access to the remote controller;
- real time monitoring;
- software upgrading.

Blueye® via Ethernet is only available for units supplied with an advanced controller and does not include any type of service. This service must be purchased separately based on the number of units/devices to be connected and the number of variables to be monitored. In order to connect multiple units to **Blueye® device, the network switch is required (this accessory is sold separately).**

Units can also be connected to the Blueeye device through the RS485 network featuring a Modbus RTU protocol (for this option, refer to BERS accessory).

For further details, refer to the specific Blueeye® documentation.

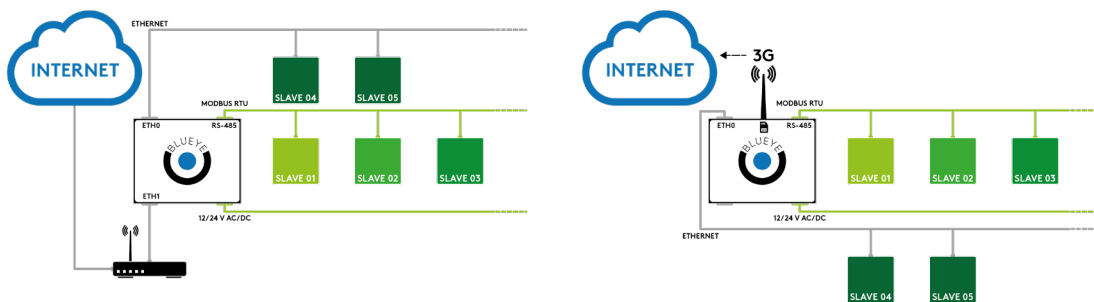

GLO Modbus Lonworks Gateway

With this accessory, a RS485/Lon gateway is installed inside the electrical control panel.

By default, the programming gives read-only access to the control of the unit. Enabling of read/write access should be requested when ordering.

FMx Multilogic Function

The Multilogic function allows management of up to 32 units equipped with advanced Bluethink controller and connected in hydraulic parallel with each other.

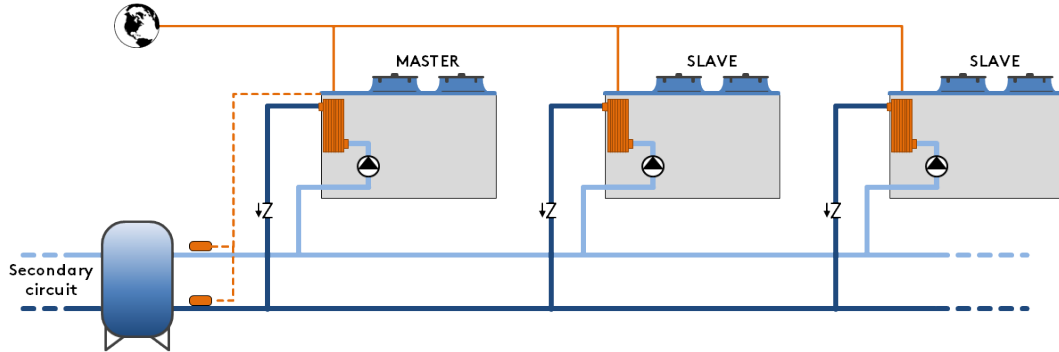

On the basis of the information recorded by the temperature probes installed on the delivery and return manifolds of the system, with the master unit, a capacity request is generated that is distributed among the units connected in the Multilogic network according to settable priority and optimization logics.

If communication between the units fails or if the master is off-line, the slave units can continue to work according to the set thermoregulation parameters.

The connected units can be different from each other, in terms of capacity and set-up, provided the following rules are complied with:

- if there are both chiller units and heat pumps in the Multilogic network, the Master unit must obligatorily be one of the HP units
- if there are both free cooling and non free-cooling units in the Multilogic network, the Master unit must obligatorily be one of the free-cooling units.

The Multilogic function that can be requested with the unit can be:

- **FM0:** Multilogic function for Slave unit
- **FM2:** Multilogic function for Master unit for managing up to 2 Slaves
- **FM6:** Multilogic function for Master unit for managing up to 6 Slaves

If you need to connect more than 6 slaves (up to 31), you can ask for a quotation from our sales department.

For the slave units, the accessory requires:

- programming of the unit as slave of a system of machines in Multilogic network

For the master units, the accessory requires:

- programming of the unit as master of a system of machines in Multilogic network
- entering of the parameters necessary for connection with the individual slave units
- installation in the electrical control panel of a network switch to allow the units to be connected in a LAN network.
- the supply of 2 temperature probes to be positioned on the delivery and return manifold of the system (supplied separately with it, installation and wiring by the customer)

The connection between the master unit and the slave units made with a CAT cable. 5E/UTP (prepared by the customer) with RJ45 connectors. Maximum cable length 100m.

For further details, please refer to the controller manual.

PBA BACnet protocol over IP (Ethernet)

The controller is set for use, in read and write mode, of the BACnet port on IP protocol.

By default, the programming gives read-only access to the control of the unit. Enabling of read/write access should be requested when ordering.

SMAR Smartlink

This accessory makes it possible to connect the controller of the unit with the controller of a Swegon GOLD™ air handling unit via a simple serial cable, so allowing their operating logics to be merged into a single consciousness that pursues the maximum energy efficiency of the system. The RS485 serial interface is already included and dedicated to connection with Swegon units.

The option is incompatible with:

- double set point
- variable set point with remote signal
- summer/winter selection by digital input
- set point compensation depending on external air temperature
- multilogic
- all communication protocols.

SW4P Network switch with 4 ports

The accessory includes installation in DIN rail of a professional 8-port network switch.

Requires Blueeye via Ethernet.

SW8P Network switch with 8 ports

The accessory includes installation in DIN rail of a professional 4-port network switch. Requires Blueeye via Ethernet.

PSN SNMP protocol

The accessory consists of a gateway that allows Ethernet connection to a SNMP manager supervision system. The use of this accessory causes the RS485 serial port to be unavailable.

Other accessories

AG Rubber anti-vibration mounts

These allow you to reduce the vibrations transmitted from the unit to the surface it is standing on. Accessory supplied loose.

ALPR Pre-painted aluminium coil

This option uses finned pack coils with copper tubes and pre-painted aluminium fins.

ANTC Coil treated with anti-corrosion paints

The treatment is applied exclusively to finned pack coils with copper tubes and aluminium fins and consists of aluminium passivation and coating with a polyurethane base; a double layer of paint, of which the first passivates the aluminium and acts as primer and the second is a polyurethane based surface coating. The product has high resistance to corrosion and all environmental conditions.

The product has high resistance to corrosion and to all environmental conditions.

Protective treatment of the exchanger is strongly recommended if at least one of the points below is verified:

- there are obvious signs of corrosion on the exposed metal surfaces in the installation area
- the installation is located close to the sea coast
- the prevailing winds come from the sea and travel in the direction of the unit
- the environment is industrial with a significant concentration of pollutants
- it is an urban environment with a high population density
- it is a rural environment with the presence of organic discharges and effluents

For chiller units, this accessory also includes the "Cu/Al coil" accessory.

With reference to the protection criteria to follow, especially for installations close to the coast, refer to the section titled "Installations that require the use of treated coils".

FW Water filter

To protect the elements of the hydraulic circuit (in particular, the exchangers), there are Y filters that can stop and settle the particles that are normally present in the water flow and would otherwise settle in the more delicate parts of the hydraulic circuit and damage its heat exchange capacity.

Installation of the water filter is mandatory even when it is not supplied as an accessory.

Accessory supplied loose.

GABB Packaging in wooden crate

The unit is protected by a custom-made wooden cage, including a wooden sled designed for loading into containers and a fixing system. The accessory can be used for container shipping. Loading on containers must be carried out at the factory. The accessory is incompatible with "Skid for shipping in containers".

SLIT Special pallet/skid for container shipment

The unit is placed on a skid that makes the container loading and unloading operations easier.

The accessory is mandatory if shipping by container is required

RAV Anti-freeze heater for condensate drip tray

A heating cable, glued to the bottom, can be combined with the condensate drip tray to prevent ice formation at the base of the coil or near the drains.

The heater is controlled by a thermostat and is activated depending on the external air temperature.

PREA Unit suitable to be disassembled on site

The unit is delivered so that it can be disassembled easily on site if this makes the installation operations easier.

A unit requested with this option is supplied:

- screwed instead of riveted
- with plugged and not welded pipes
- without refrigerant charge
- untested
- covered by the warranty only if reassembled and screwed together by personnel authorized by the factory

TECHNICAL SPECIFICATIONS

ZETA REV HP XT

			3.2	4.2	5.2	6.2	7.2	8.2	9.2
Cooling (A35°C; W7°C)									
Refrigeration capacity	(1)	kW	37,6	46,6	52,7	61,7	72	80,5	91,2
Total absorbed power	(1)	kW	12,6	15,7	18,0	20,4	24,2	27,2	31,0
EER	(1)		2,99	2,96	2,93	3,02	2,97	2,96	2,94
EER energy class (Eurovent)	(1)		B	B	B	B	B	B	B
ESEER	(7)		3,79	3,68	3,90	3,89	3,89	3,94	3,84
Heating (A7°C/87%; W45°C)									
Heating capacity	(2)	kW	42,2	52,3	57,7	71	80,1	85,7	104,8
Total absorbed power	(2)	kW	12,1	15,0	16,5	20,3	22,9	24,6	30,6
COP	(2)		3,50	3,49	3,50	3,49	3,49	3,49	3,42
COP energy class (Eurovent)	(2)		A	A	A	A	A	A	A
Compressors									
Compressors/Circuits		n°/n°	2/1	2/1	2/1	2/1	2/1	2/1	2/1
Minimum capacity reduction step	(6)	%	50%	50%	50%	50%	50%	50%	50%
Refrigerant charge	(8)	kg	12	18	19	28	28	32	43
Oil charge		kg	4	4	7	7	7	7	7
Fans									
Quantity		n°	2	2	2	3	3	3	2
Total air flow rate		m ³ /h	17.000	19.000	19.000	28.000	28.000	28.000	42.000
User-side heat exchanger									
Quantity		n°	1	1	1	1	1	1	1
Water content		l	4,0	4,0	5,5	5,5	6,0	9,8	9,8
Water flow rate (A35°C; W7°C)	(1)	m ³ /h	6,5	8,0	9,1	10,7	12,4	13,9	15,7
Head loss (A35°C; W7°C)	(1)	kPa	20	29	23	33	34	7	10
Water flow rate (A7°C; W45°C)	(2)	m ³ /h	7,2	9	9,9	12,1	13,7	14,7	18
Head loss (A7°C; W45°C)	(2)	kPa	21	31	24	35	37	8	10
Noise levels									
Sound power level cooling	(3)	dB(A)	81	81	82	82	83	83	84
Sound pressure level cooling	(4)	dB(A)	50	50	51	50	51	51	52
Sound power level heating	(5)	dB(A)	81	81	82	82	83	83	84
Sound power level during cooling LN	(3)	dB(A)	79	79	80	80	81	81	82
Sound pressure level during cooling LN	(4)	dB(A)	48	48	49	48	49	49	50
Sound power level during heating LN	(5)	dB(A)	79	79	80	80	81	81	82
Dimensions and weights**									
Length		mm	1.750	2.200	2.200	3.200	3.200	3.200	3.200
Depth		mm	1.000	1.000	1.000	1.100	1.100	1.100	1.100
Height		mm	1.400	1.740	1.740	1.740	1.740	1.740	2.380
Operating weight		kg	464	639	649	721	731	859	1174

- (1) External air temperature of 35°C and user-side heat exchanger water inlet-outlet temperature of 12-7°C. Values compliant with standard EN 14511
- (2) Outside air temperature 7°C DB, 6°C WB; condenser inlet/outlet water temperature 40/45°C. Values compliant with standard EN 14511
- (3) Unit operating at rated capacity, with no accessories of any kind - external air temperature 35°C and water input/output temperature from/to heat exchanger and user equal to 12/7°C. Values taken by measurements made in accordance with standard ISO 3744 and the Eurovent certification programme, where applicable. Binding values See NOISE LEVELS section.
- (4) Values obtained from the sound power level (conditions: note 3), related to a distance of 10 m from the unit in free field with directivity factor Q=2. Non-binding values See NOISE LEVELS section.
- (5) Unit operating at nominal operating capacity, with no options of any kind, with outside air temperature of 7°C (6°C wb) and input/output water temperature into/from user-side heat exchanger 47/55°C, climate profile "Average", in accordance with regulation 2013/813 and standard EN 14825
- (6) Approximate value. The minimum capacity reached by the unit depends on the operating conditions. The value shown may not be suitable for calculating the minimum volume of water: to do this, consult the "Minimum water content in the system" section.
- (7) Former Eurovent's seasonal efficiency index. Value not certified by Eurovent from 2019. Reference: base unit, without any accessories
- (8) The indicated refrigerant charge is calculated. The refrigerant charge can vary according to different versions/accessories and product updates.

** Basic unit without included accessories

ZETA REV HP XT

			10.4	12.4	14.4	16.4	18.4
Cooling (A35°C; W7°C)							
Refrigeration capacity	(1)	kW	107,3	126,3	145,4	161,4	183,7
Total absorbed power	(1)	kW	36,6	42,3	49,7	56,1	66,3
EER	(1)		2,93	2,99	2,92	2,88	2,77
EER energy class (Eurovent)	(1)		B	B	B	C	C
ESEER	(7)		3,91	3,80	3,79	3,74	3,66
Heating (A7°C/87%; W45°C)							
Heating capacity	(2)	kW	118	145,1	161	174,4	204,4
Total absorbed power	(2)	kW	34,4	42,7	47,6	51,9	61,6
COP	(2)		3,43	3,40	3,38	3,36	3,32
COP energy class (Eurovent)	(2)		A	A	A	A	A
Compressors							
Compressors/Circuits		n°/n°	4/2	4/2	4/2	4/2	4/2
Minimum capacity reduction step	(6)	%	25%	25%	25%	25%	25%
Refrigerant charge	(8)	kg	52	67	68	68	70
Oil charge		kg	14	14	14	14	14
Fans							
Quantity		n°	2	3	3	3	4
Total air flow rate		m ³ /h	42.000	63.000	63.000	63.000	84.000
User-side heat exchanger							
Quantity		n°	1	1	1	1	1
Water content		l	9,4	9,4	11,9	11,9	13,3
Water flow rate (A35°C; W7°C)	(1)	m ³ /h	18,5	21,8	25,1	27,9	31,7
Head loss (A35°C; W7°C)	(1)	kPa	23	33	26	33	35
Water flow rate (A7°C; W45°C)	(2)	m ³ /h	20,2	24,9	27,6	29,9	35
Head loss (A7°C; W45°C)	(2)	kPa	26	36	30	36	39
Noise levels							
Sound power level cooling	(3)	dB(A)	85	85	86	86	87
Sound pressure level cooling	(4)	dB(A)	53	53	54	54	55
Sound power level heating	(5)	dB(A)	85	85	86	86	87
Sound power level during cooling LN	(3)	dB(A)	83	83	84	84	85
Sound pressure level during cooling LN	(4)	dB(A)	51	51	52	52	53
Sound power level during heating LN	(5)	dB(A)	83	83	84	84	85
Dimensions and weights**							
Length		mm	4.200	4.200	4.200	4.200	4.200
Depth		mm	1.100	1.100	1.100	1.100	1.100
Height		mm	2.380	2.380	2.380	2.380	2.380
Operating weight		kg	1615	1743	1780	1772	1793

- (1) External air temperature of 35°C and user-side heat exchanger water inlet-outlet temperature of 12-7°C. Values compliant with standard EN 14511
- (2) Outside air temperature 7°C DB, 6°C WB; condenser inlet/outlet water temperature 40/45°C. Values compliant with standard EN 14511
- (3) Unit operating at rated capacity, with no accessories of any kind - external air temperature 35°C and water input/output temperature from/to heat exchanger and user equal to 12/7°C. Values taken by measurements made in accordance with standard ISO 3744 and the Eurovent certification programme, where applicable. Binding values See NOISE LEVELS section.
- (4) Values obtained from the sound power level (conditions: note 3), related to a distance of 10 m from the unit in free field with directivity factor Q=2. Non-binding values See NOISE LEVELS section.
- (5) Unit operating at nominal operating capacity, with no options of any kind, with outside air temperature of 7°C (6°C wb) and input/output water temperature into/from user-side heat exchanger 47/55°C, climate profile "Average", in accordance with regulation 2013/813 and standard EN 14825
- (6) Approximate value. The minimum capacity reached by the unit depends on the operating conditions. The value shown may not be suitable for calculating the minimum volume of water: to do this, consult the "Minimum water content in the system" section.
- (7) Former Eurovent's seasonal efficiency index. Value not certified by Eurovent from 2019. Reference: base unit, without any accessories
- (8) The indicated refrigerant charge is calculated. The refrigerant charge can vary according to different versions/accessories and product updates.
- ** Basic unit without included accessories

ECODESIGN

INTRODUCTION

The Ecodesign/ErP Directive (2009/125/EC) lays down new standards for more efficient energy use.

The Directive contains various regulations; as regards chiller products and heat pumps, the regulations of interest are the following:

- Regulation 2013/813, for small heat pumps ($P_{\text{design}} \leq 400$ kW)
- Regulation 2016/2281, for chillers and heat pumps with $P_{\text{design}} > 400$ kW
- Regulation 2013/811, for heat pumps with $P_{\text{design}} \leq 70$ kW.

The last-mentioned regulation (2013/811) regards the labelling (Ecolabel certification) of small heat pumps.

The other two regulations (2013/813 and 2016/2281) set seasonal efficiency targets that the products must comply with to be sold and installed in the European Union (essential requirement for CE marking).

These efficiency limits are defined through ratios, which are respectively:

- η_{sh} (SCOP), with reference to regulation 2013/813
- η_{sc} (SEER) for comfort applications and SEPR for process applications, with reference to regulation 2016/2281.

As regards regulation 2016/2281, with effect from 1st January 2021, the required minimum efficiency limit will be raised (Tier 2) from the current threshold (Tier 1).

The figure below schematically illustrates the correspondence between product and reference energy ratio.

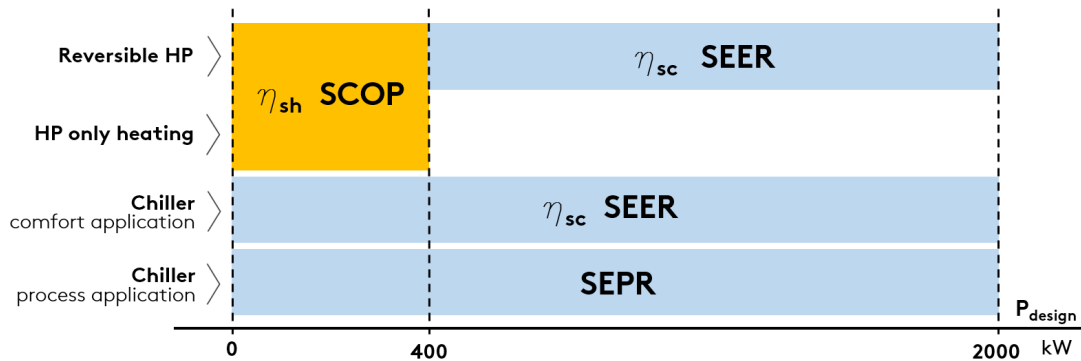

Some notes and clarifications:

For comfort applications, regulation 2016/2281 sets the η_{sc} (SEER) ratio in two different operating conditions:

- SEER calculated with machine inlet/outlet water temperature of 12/7°C (low temperature application),
- SEER calculated with machine inlet/outlet water temperature of 23/18°C (medium temperature application).

The minimum efficiency requirement is the same, but can be met at condition 12/7°C or at condition 23/18°C, depending on the application envisaged for the machine.

Regulation 2013/813 distinguishes two different types: at low temperature and at medium temperature.

The following refer to the application at low temperature: (low temperature application) all heat pumps whose maximum delivery temperature for heating purposes is lower than 52°C with source at temperature of -7°C and -8°C wet bulb (air-water unit) or inlet 10°C (water-water unit), at the reference design conditions for an average climate. For these, the efficiency ratio is "low temperature application" (outlet water temperature 35°C).

For all the other heat pumps, the efficiency ratio is related to "medium temperature application" (outlet water temperature 55°C).

The ratios must be calculated according to the reference European heating season in average climatic conditions.

The minimum efficiency requirements set by the regulations are indicated below.

REGULATION 2016/2281, comfort application

TYPE OF UNIT		MINIMUM REQUIREMENT			
		Tier 1		Tier 2 (2021)	
SOURCE	P _{design}	η _{sc} [%]	SEER	η _{sc} [%]	SEER
air	< 400kW	149	3,8	161	4,1
air	≥ 400kW	161	4,1	179	4,55
water	< 400kW	196	5,1	200	5,2
water	≥ 400kW and < 1500kW	227	5,875	252	6,5
water	≥ 1500kW	245	6,325	272	7

REGULATION 2016/2281, process application

TYPE OF UNIT		MINIMUM REQUIREMENT	
		Tier 1	Tier 2 (2021)
SOURCE	P _{design}	SEPR	SEPR
air	< 400kW	4,5	5
air	≥ 400kW	5	5,5
water	< 400kW	6,5	7
water	≥ 400kW and < 1500kW	7,5	8
water	≥ 1500kW	8	8,5

REGULATION 2013/813

SOURCE	APPLICATION	MINIMUM REQUIREMENT	
		η _{sh} [%]	SCOP
air	low temperature application	125	3,2
water	low temperature application	125	3,325
air	medium temperature application	110	2,825
water	medium temperature application	110	2,95

The conformity of the product must be checked according to the type of application, whether comfort or process, and at the required outlet water temperature.

The two schematic tables below, respectively for comfort application and for process application, indicate the reference of the required conformity according to the type of product and the set point temperature (reference to regulations 2016/2281 and 2013/813).

Important note: for mixed comfort and process applications, the reference application for conformity is the comfort application.

COMFORT APPLICATION

PRODUCT	OUTLET WATER TEMPERATURE	COMPLIANCE INDEX	REGULATION
Chiller	< 18°C	SEER/η _{sc} low temperature application	2016/2281
	≥ 18°C	SEER/η _{sc} medium temperature application	2016/2281
Heat pumps (reversible and only heating) P_{design} ≤ 400kW		SCOP/η _{sh}	2013/813
Reversible heat pumps P_{design} > 400kW	< 18°C	SEER/η _{sc} low temperature application	2016/2281
	≥ 18°C	SEER/η _{sc} medium temperature application	2016/2281
Heat pumps only heating P_{design} > 400kW		-	-

- = exemption from Ecodesign

PROCESS APPLICATION

PRODUCT	OUTLET WATER TEMPERATURE	COMPLIANCE INDEX	REGULATION
Chiller	≥ +2°C , ≤ 12°C	SEPR	2016/2281
	> 12°C	-	-
	> -8°C , < +2°C	-	-

- = exemption from Ecodesign

Some specifications and notes follow.

Partly completed machinery

The term partly completed machinery refers to all units without a user-side or source-side heat exchanger, and therefore to all LC, LE, LC/HP and LE/HP versions. Since these are "non-complete" machines, conformity with Ecodesign depends on combination with the remote heat exchanger.

All the partly completed machinery is CE marked and accompanied by a declaration of conformity. Installation in European Union countries is therefore allowed; correct selection and installation of the remote heat exchanger must be ensured, in accordance with the above cases.

EC fans:

The only option that positively affects the performance of the unit, by increasing its seasonal energy efficiency ratio, is the VEC accessory.

A unit equipped with EC fans has a higher SEER (η_{sc}) than the configuration with standard fans.

ZETA REV HP XT RANGE

As specifically regards the Zeta Rev HP XT range, the regulations of interest for the various units in various configurations are indicated below. regulation 2013/813 (since they are all units with Pdesign ≤ 400 kW).

All units are compliant with Ecodesign as regards average temperature applications, according to climate profile "Average", in accordance with standard EN 14825.

The tables below give information on the conformity of the units and the seasonal energy performance ratios with regard to the reference regulation.

ZETA REV HP XT

			3.2	4.2	5.2	6.2	7.2	8.2	9.2
REGULATION 2013/813									
Pdesign	(1)	kW	40,3	49,4	53,7	67,9	75,6	81,6	99,8
COMFORT									
Average temperature application									
ηsh	(1)	%	116,2	117,6	120,3	120	120,9	121,7	116,1
SCOP	(1)		2,98	3,02	3,08	3,08	3,1	3,12	2,98
Conformity with Tier 2	(1)		Y	Y	Y	Y	Y	Y	Y
Low temperature application									
ηsh	(2)	%	131,7	131,6	143,5	138,2	137,6	140,9	131,8
SCOP	(2)		3,37	3,37	3,66	3,53	3,51	3,6	3,37
Conformity with Tier 2	(2)		Y	Y	Y	Y	Y	Y	Y
REGULATION 2013/811									
Ecolabel	(3)		A+	A+	A+	-	-	-	-
			10.4	12.4	14.4	16.4	18.4		
REGULATION 2013/813									
Pdesign	(1)	kW	113,2	139,3	154,2	159,4	198,7		
COMFORT									
Average temperature application									
ηsh	(1)	%	118,9	114,2	116,6	113,7	115,6		
SCOP	(1)		3,05	2,93	2,99	2,92	2,97		
Conformity with Tier 2	(1)		Y	Y	Y	Y	Y		
Low temperature application									
ηsh	(2)	%	137,3	128,3	130,5	130,8	129,7		
SCOP	(2)		3,51	3,28	3,34	3,34	3,32		
Conformity with Tier 2	(2)		Y	Y	Y	Y	Y		
REGULATION 2013/811									
Ecolabel	(3)		-	-	-	-	-		

Y = unit in compliance with Ecodesign at the indicated condition.

- (1) User-side heat exchanger water inlet/outlet temperature 47/55°C, Average climate profile, with reference to regulation 2013/813 and norm EN 14825.
- (2) User-side heat exchanger water inlet/outlet temperature 30/35°C, Average climate profile, with reference to regulation 2013/813 and norm EN 14825.
- (3) Energy efficiency class with reference to Regulation 2013/811, conditions in Note 1 (average temperature applications).

ELECTRICAL SPECIFICATIONS

ZETA REV HP XT

			3.2	4.2	5.2	6.2	7.2	8.2
General electrical specifications								
Max. absorbed power (FLI)	(1)	kW	20	23	28	33	38	40
Max. absorbed current (FLA)	(1)	A	37	42	47	60	73	74
Rated current (Inom)	(2)	A	27	32	34	43	54	56
cosφ standard unit	(2)		0,85	0,85	0,85	0,85	0,84	0,83
Nominal current with power factor correction (Inom)	(2)	A	23	28	30	38	46	48
cosφ unit with power factor correction	(2)		0,97	0,97	0,97	0,97	0,98	0,98
Max. inrush current (MIC)	(3)	A	122	152	144	174	214	215
Maximum inrush current with soft-starter (MIC)	(4)	A	82	101	97	118	145	145
Power supply		V/ph/Hz	400/3~+N/50					
Power supply for auxiliary circuits		V/ph/Hz	230-24/1~/50					
Suggested line section	(5)		5G10 mm2 FG16OR16	5G16 mm2 FG16OR16			5G25 mm2 FG16OR16	
Suggested line protection	(6)		NH00gG 50A	NH00gG 63A		NH00gG 80A	NH00gG 100A	
Electrical specifications for fans								
Rated power of fan standard		n° x kW	2 x 0,6	2 x 0,6	2 x 0,6	3 x 0,6	3 x 0,6	3 x 0,6
Rated current of fan standard		n° x A	2 x 2,6	2 x 2,6	2 x 2,6	3 x 2,6	3 x 2,6	3 x 2,6
Rated power of fan EC		n° x kW	2 x 0,8	2 x 0,8	2 x 0,8	3 x 0,8	3 x 0,8	3 x 0,8
Rated current of fan EC		n° x A	2 x 1,4	2 x 1,4	2 x 1,4	3 x 1,4	3 x 1,4	3 x 1,4
Rated power of fan Oversized EC		n° x kW	2 x 1,0	2 x 1,0	2 x 1,0	3 x 1,0	3 x 1,0	3 x 1,0
Rated current of fan Oversized EC		n° x A	2 x 1,6	2 x 1,6	2 x 1,6	3 x 1,6	3 x 1,6	3 x 1,6
			9.2	10.4	12.4	14.4	16.4	18.4
General electrical specifications								
Max. absorbed power (FLI)	(1)	kW	47	57	68	79	83	94
Max. absorbed current (FLA)	(1)	A	83	93	117	143	145	167
Rated current (Inom)	(2)	A	64	67	85	107	111	128
cosφ standard unit	(2)		0,84	0,84	0,84	0,84	0,85	0,85
Nominal current with power factor correction (Inom)	(2)	A	51	55	71	87	91	106
cosφ unit with power factor correction	(2)		0,98	0,97	0,97	0,97	0,95	0,96
Max. inrush current (MIC)	(3)	A	214	190	231	284	286	297
Maximum inrush current with soft-starter (MIC)	(4)	A	147	142	175	215	216	230
Power supply		V/ph/Hz	400/3~/50					
Power supply for auxiliary circuits		V/ph/Hz	230-24/1~/50					
Suggested line section	(5)		4G25 mm2 FG16OR16	4G35 mm2 FG16OR16	3x50+1G25 mm2 FG16OR16	3x70+1G35 mm2 FG16OR16		
Suggested line protection	(6)		NH00gG 100A	NH00gG 125A	NH00gG 160A	NH1gG 200A		
Electrical specifications for fans								
Rated power of fan standard		n° x kW	2 x 2,0	2 x 2,0	3 x 2,0	3 x 2,0	3 x 2,0	4 x 2,0
Rated current of fan standard		n° x A	2 x 4,3	2 x 4,3	3 x 4,3	3 x 4,3	3 x 4,3	4 x 4,3
Rated power of fan EC		n° x kW	2 x 1,9	2 x 1,9	3 x 1,9	3 x 1,9	3 x 1,9	4 x 1,9
Rated current of fan EC		n° x A	2 x 2,9	2 x 2,9	3 x 2,9	3 x 2,9	3 x 2,9	4 x 2,9
Rated power of fan Oversized EC		n° x kW	2 x 3,0	2 x 3,0	3 x 3,0	3 x 3,0	3 x 3,0	4 x 3,0
Rated current of fan Oversized EC		n° x A	2 x 4,5	2 x 4,5	3 x 4,5	3 x 4,5	3 x 4,5	4 x 4,5

- (1) Data regarding the unit without accessories working in maximum power absorption conditions
- (2) Datum related to the unit without accessories working in standard conditions (A35°C; W12/7°C)
- (3) Maximum effective RMS value of the current when the last compressor starts (FLA of the entire unit - FLA of the largest compressor + LRA of the largest compressor)
- (4) Maximum effective RMS value of the current when the last compressor starts (FLA of the entire unit - FLA of the largest compressor + 0.6 x LRA of the largest compressor)
- (5) These values are determined for cables with operating temperature of 40°C, EPR insulation and a line with a maximum length of 50m. The line section must be determined by a qualified technician based on the protection devices, the length of the line, the type of cable used and the type of installation.
- (6) The correct line protection part must be determined by a qualified technician based on the length of the line, the type of cable used and the type of installation.

HYDRAULIC MODULES

ZETA REV HP XT

			3.2	4.2	5.2	6.2	7.2	8.2
Volume of the expansion vessel		l	5	18	18	18	18	18
Volume of the buffer tank		l	165	190	190	450	450	450
Standard pumps								
Pump model 1P, 2P			P1	P3	P3	P3	P3	P3
Available head 1P	(1)	kPa	124	125	126	110	102	120
Available head 2P	(1)	kPa	109	115	113	103	93	109
Oversize pumps								
Pump model 1PM, 2PM			P2	P4	P4	P4	P4	P4
Available head 1PM	(1)	kPa	208	206	208	194	186	205
Available head 2PM	(1)	kPa	194	196	195	187	177	194
			9.2	10.4	12.4	14.4	16.4	18.4
Volume of the expansion vessel		l	18	18	18	18	18	18
Volume of the buffer tank		l	390	390	700	700	700	700
Standard pumps								
Pump model 1P, 2P			P5	P6	P9	P9	P10	P10
Available head 1P	(1)	kPa	121	137	115	112	159	141
Available head 2P	(1)	kPa	105	117	106	101	145	122
Oversize pumps								
Pump model 1PM, 2PM			P7	P8	P11	P11	P12	P12
Available head 1PM	(1)	kPa	198	229	223	221	281	264
Available head 2PM	(1)	kPa	182	209	214	209	267	245

(1) External air temperature 35°C, user-side heat exchanger water inlet/outlet temperature 12/7°C. Values in accordance with EN 14511.

PUMP DATA

Model	Rated power	Rated current	Qmin	Qmax
	kW	A	m ³ /h	m ³ /h
P1	0,6	1,6	0,0	10,6
P2	0,9	2,4	0,0	10,6
P3	0,8	1,9	7,0	19,8
P4	1,5	3,2	7,0	19,8
P5	1,1	2,4	12,0	28,6
P6	1,5	3,4	12,0	31,7
P7	1,9	4,5	12,0	34,3
P8	3,0	5,9	12,0	34,3
P9	1,5	3,2	12,0	50,8
P10	2,2	4,5	12,0	50,8
P11	3,0	6,1	12,0	50,8
P12	4,0	8,7	12,0	50,8

USER-SIDE EXCHANGER FLOW RATE FIELDS

The units are sized and optimized for the following nominal conditions: external air 35°C, inlet-outlet of the user-side exchanger 12/7°C.

The units can work at design conditions different from nominal conditions, provided that:

- the design condition falls within the operating limits specified below
- the flow rate at design conditions (that is, of the specific application) must always come within the allowed flow rate ranges specified below. If the design conditions require a water flow rate that does not come within the allowed operating range, you must contact our sales department that will identify the most suitable solution for the specific application.

The temperature limits for heating operation are related to machine and plant in perfect efficiency and optimal conditions. In practice, this is influenced by the condition of the exchanger, the flow rate and mass of water in the plant, the maneuvers carried out by the users and other non-controllable factors.

The maximum heating/sanitary operating temperature must be defined in relation to the above conditions. These may require an indicative reduction of the set-point of about 2K referred to the maximum limit.

It is recalled that the temperature limits are related to the delivery of the unit itself, thus considering no thermal exchange downstream of this.

ZETA REV HP XT

	Qmin	Qmax
	m ³ /h	m ³ /h
3.2	3,2	9,7
4.2	4,0	12,1
5.2	4,6	13,7
6.2	5,3	16,0
7.2	6,2	18,7
8.2	6,9	20,8
9.2	7,9	23,6
10.4	9,3	27,8
12.4	10,9	32,7
14.4	12,5	37,6
16.4	13,9	41,8
18.4	15,9	47,6

OPERATING LIMITS

COOLING

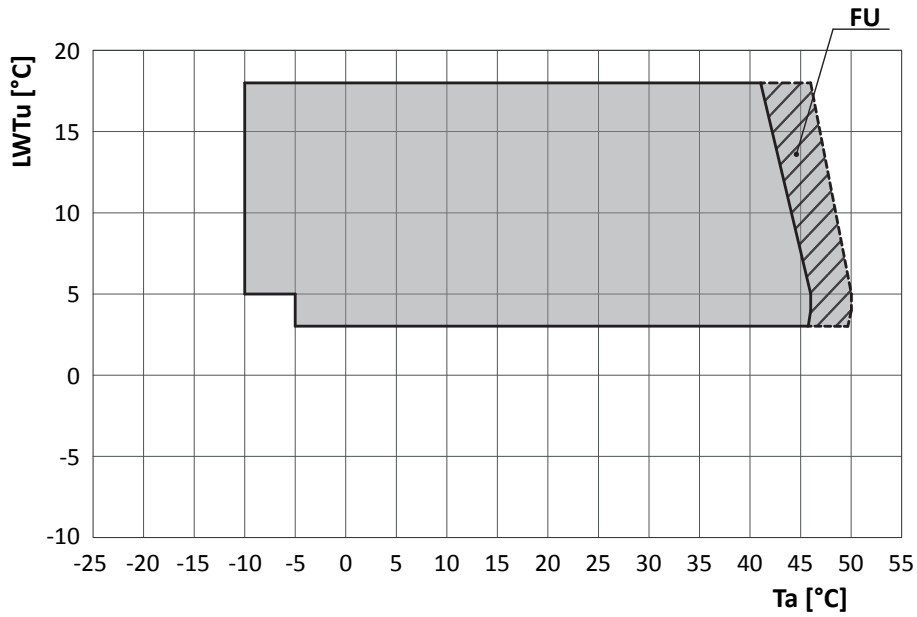

HEATING

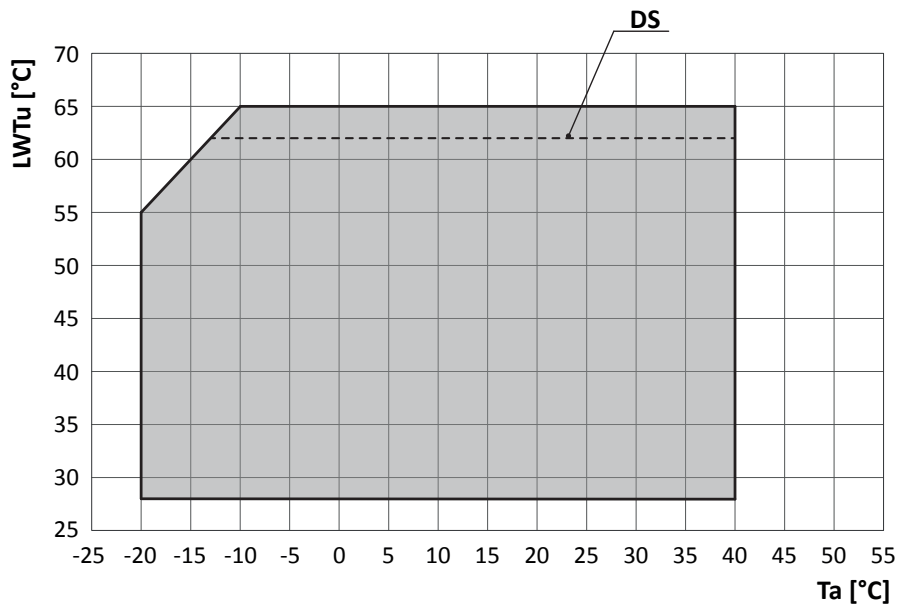

Ta: external air temperature

LWTu: water outlet temperature from the user-side heat exchanger

FU: in the indicated area, the control could actuate a forced capacity reduction of the compressors so as to prevent tripping of the safety devices

DS: When a desuperheater (option DS) is fitted, irrespective of it running in either cooling or heating mode, the max. LWTu_Heating temperature is reduced to 62°C.

For LWTu below +5°C, it is compulsory to use suitable percentages of antifreeze additives (glycols) to prevent ice formation in the exchanger.

The inlet and outlet temperatures of the user-side exchanger must be given on ordering to allow correct setting of the alarm parameters and verification of the sizing of the expansion valve.

The cooling set point can then be changed by the customer in an interval that, compared to the set point given on ordering, ranges from -1K up to the maximum temperature allowed by the above-stated operating limits.

The unit will be optimized to work at the set point temperatures given on ordering. For different set points, the cooling capacity provided and the level of efficiency of the machine could decrease and move away from these conditions.

NOISE LEVELS

ZETA REV HP XT

	Octave bands [dB]																Total [dB(A)]	
	63 Hz		125 Hz		250 Hz		500 Hz		1000 Hz		2000 Hz		4000 Hz		8000 Hz		Lw_tot	Lp_tot
	Lw	Lp	Lw	Lp	Lw	Lp	Lw	Lp	Lw	Lp	Lw	Lp	Lw	Lp	Lw	Lp		
3.2	78	47	78	46	69	37	69	38	75	44	74	43	75	44	71	40	81	50
4.2	81	50	80	49	71	40	72	41	76	45	74	43	74	43	69	37	81	50
5.2	80	49	79	47	71	39	74	43	75	43	78	46	73	42	72	40	82	51
6.2	82	50	81	49	72	40	74	42	76	44	77	45	73	41	72	40	82	50
7.2	81	49	80	48	72	40	73	41	75	43	79	47	75	43	73	41	83	51
8.2	82	50	81	49	72	40	75	43	76	44	78	46	75	43	73	41	83	51
9.2	87	55	77	45	75	43	78	46	78	46	79	47	74	42	71	39	84	52
10.4	87	55	77	45	75	43	78	46	78	46	81	49	76	44	74	42	85	53
12.4	88	56	78	46	76	44	79	47	79	47	80	48	76	44	75	43	85	53
14.4	88	56	78	46	76	44	78	46	78	46	82	50	77	45	76	44	86	54
16.4	89	57	79	47	77	45	79	47	79	47	81	49	78	46	76	44	86	54
18.4	90	58	80	48	78	46	81	49	81	49	82	50	77	45	74	42	87	55

ZETA REV HP XT /LN

	Octave bands [dB]																Total [dB(A)]	
	63 Hz		125 Hz		250 Hz		500 Hz		1000 Hz		2000 Hz		4000 Hz		8000 Hz		Lw_tot	Lp_tot
	Lw	Lp	Lw	Lp	Lw	Lp	Lw	Lp	Lw	Lp	Lw	Lp	Lw	Lp	Lw	Lp		
3.2	76	45	76	44	67	35	68	36	73	42	72	41	73	42	69	38	79	48
4.2	79	47	78	47	69	38	70	39	74	43	72	41	72	41	67	35	79	48
5.2	78	47	77	45	69	37	72	41	73	41	76	44	71	40	70	38	80	49
6.2	80	48	79	47	70	38	72	40	74	42	75	43	71	39	70	38	80	48
7.2	79	47	78	46	70	38	71	39	73	41	77	45	73	41	71	39	81	49
8.2	80	48	79	47	70	38	73	41	74	42	76	44	73	41	71	39	81	49
9.2	85	53	75	43	73	41	76	44	76	44	77	45	72	40	69	37	82	50
10.4	85	53	75	43	73	41	76	44	76	44	78	46	74	42	72	40	83	51
12.4	86	54	76	44	74	42	77	45	77	45	78	46	74	42	73	41	83	51
14.4	86	54	76	44	74	42	76	44	77	45	80	48	76	44	74	42	84	52
16.4	87	55	77	45	75	43	77	45	77	45	79	47	76	44	74	42	84	52
18.4	88	56	78	46	76	44	79	47	79	47	80	48	75	43	72	40	85	53

Reference conditions: outside air temperature 35°C; input/output water temperature into/from user-side heat exchanger 12/7°C; unit operating at rated capacity, without any option.

Lw: sound power levels.

Values obtained from measures taken according to standard ISO 3744.

Lw_tot is the only binding value.

Lp: sound pressure levels.

Binding values starting from noise power levels referred to a distance of 10 m from the unit; source installed on a reflective surface and in ideal free field conditions with directivity factor Q=2. Non-binding values

The acoustic data are related to standard conditions in referable and reproducible operating conditions. All data with the exception of Lw_tot are provided for illustrative purposes only and can not be used for forecasting purposes or for the verification of binding limits.

With special reference to noise emissions, the Manufacturer takes liability for their conformity, limited to the declared Lw_tot value. Any and all other Manufacturer's liability for the impact of such emissions in relation to the location of the machine and other conditions related to machine installation is excluded. The environment and the installation conditions, as well as the operating modes, can alter the sound emissions. Any assessment concerning these conditions falls within the area of competence of the plant designer and/or the fitter.

CONFIGURATIONS THAT ARE NOT POSSIBLE

	/1Px	/2Px	/1PxS	/2PxS	/DS / 1Px	/DS / 2Px	/DS / 1PxS	/DS / 2PxS
3.2								
4.2		n.a.		n.a.		n.a.		n.a.
5.2		n.a.		n.a.		n.a.		n.a.
6.2								
7.2								
8.2								
9.2								
10.4								
12.4			(1)	(1)			(1)	(1)
14.4			(1)	(1)			(1)	(1)
16.4			(1)	(1)			(1)	(1)
18.4			(1)	(1)			(1)	(1)

n.a. Configuration not available

(1) The unit is built on a larger frame than the standard

INSTALLATION ADVICE

The units described in this document are, by nature, strongly affected by the characteristics of the system, the working conditions and the installation site.

Remember that the unit must be installed by a qualified and skilled technician, and in compliance with the national legislation in force in the destination country.

The installation must be done in such a way that it will be possible to carry out all routine and non-routine maintenance operations.

Before starting any work, you must carefully read the "Installation, operation and maintenance manual" of the machine and do the necessary safety checks to prevent any malfunctioning or hazards.

We give some advice below that will allow you to increase the efficiency and reliability of the unit and therefore of the system into which it is inserted.

Water characteristics

To preserve the life of the exchangers, the water is required to comply with some quality parameters and it is therefore necessary to make sure its values fall within the ranges indicated in the following table:

Total hardness	2,0 ÷ 6,0 °f
Langelier index	- 0,4 ÷ 0,4
pH	7,5 ÷ 8,5
Electrical conductivity	10 ÷ 500 µS/cm
Organic elements	-
Hydrogen carbonate (HCO₃⁻)	70 ÷ 300 ppm
Sulphates (SO₄²⁻)	< 50 ppm
Hydrogen carbonate / Sulphates (HCO₃⁻/SO₄²⁻)	> 1
Chlorides (Cl⁻)	< 50 ppm
Nitrates (NO₃⁻)	< 50 ppm
Hydrogen sulphide (H₂S)	< 0,05 ppm
Ammonia (NH₃)	< 0,05 ppm
Sulphites (SO₃), free chlorine (Cl₂)	< 1 ppm
Carbon dioxide (CO₂)	< 5 ppm
Metal cations	< 0,2 ppm
Manganese ions (Mn⁺⁺)	< 0,2 ppm
Iron ions (Fe²⁺ , Fe³⁺)	< 0,2 ppm
Iron + Manganese	< 0,4 ppm
Phosphates (PO₄³⁻)	< 2 ppm
Oxygen	< 0,1 ppm

Installation of water filters on all the hydraulic circuits is obligatory.

The supply of the most suitable filters for the unit can be requested as accessory. In this case, the filters are supplied loose and must be installed by the customer following the instructions given in the installation, operation and maintenance manual.

Glycol mixtures

With temperatures below 5°C, it is mandatory to work with water and anti-freeze mixtures, and also change the safety devices (anti-freeze, etc.), which must be carried out by qualified authorised personnel or by the manufacturer.

Liquid outlet temperature or minimum ambient temperature	°C	0	-5	-10	-15	-20	-25	-30	-35	-40
Freezing point	°C	-5	-10	-15	-20	-25	-30	-35	-40	-45
Ethylene glycol	%	6	22	30	36	41	46	50	53	56
Propylene glycol	%	15	25	33	39	44	48	51	54	57

The quantity of antifreeze should be considered as % on weight

Minimum water content in the system

For correct operation of the unit, it is necessary to ensure a buffering on the system such as to comply with the minimum operating time considering the greater between the minimum OFF time and the minimum ON time. In short, these contribute to limiting the number of times the compressors are switched on per hour and to preventing undesired deviations from the set point of the delivered water temperature.

The following experimental formula allows the minimum water volume of the system to be calculated:

$$V_{min} = \frac{P_{tot} \cdot 1.000}{N} \cdot \frac{300}{\Delta T \cdot \rho \cdot c_p} + P_{tot} \cdot 0,25$$

where

V_{min} is the minimum water content of the system [l]

P_{tot} is the total cooling capacity of the machine [kW]

N: number of capacity reduction steps

ΔT : differential allowed on the water temperature. Unless otherwise specified, this value is considered to be 2.5K

ρ : density of the heat-carrying fluid. Unless otherwise specified, the density of water is considered

c_p : specific heat of the heat-carrying fluid. Unless otherwise specified, the specific heat of water is considered

Considering the use of water and grouping together some terms, the formula can be re-written as follows:

$$V_{min} = \frac{P_{tot}}{N} \cdot 17,2 + P_{tot} \cdot 0,25$$

N is equal to the number of compressors installed in the unit.

Larger amounts of water are in any case always preferable, because they allow a smaller number of starts and switch-offs of the compressors, less wear of them and an increase in the efficiency of the system as a consequence of a reduction in the number of transients.

It should also be pointed out that, for air-water units working in heat pump mode, the minimum amount of water must consider the need of the unit to carry out defrosting. Having an adequate buffering volume will allow prevention of too high drifts of the delivered water temperature at the end of the defrost cycle.

Installation site

To determine the best installation site for the unit and its orientation, you should pay attention to the following points:

- compliance with the clearance spaces indicated in the official dimensional drawing of the unit must be guaranteed so as to ensure accessibility for routine and non-routine maintenance operations
- you should consider the origin of the hydraulic pipes and their diameters because these affect the radiuses of curvature and therefore the spaces needed for installing them
- you should consider the position of the cable inlet on the electrical control panel of the unit as regards the origin of the power supply
- if the installation includes several units side by side, you should consider the position and dimensions of the manifolds of the user-side exchangers and of any recovery exchangers
- if the installation includes several units side by side, you should consider that the minimum distance between units is 3 metres
- you should avoid all obstructions that can limit air circulation to the source-side exchanger or that can cause recirculation between air supply and intake
- you should consider the orientation of the unit to limit, as far as possible, exposure of the source-side exchanger to solar radiation
- if the installation area is particularly windy, the orientation and positioning of the unit must be such as to avoid air recirculation on the coils. If necessary, we advise making windbreak barriers in order to prevent malfunctioning.

Once the best position for the unit has been identified, you must check that the support slab has the following characteristics:

- its dimensions must be proportionate to those of the unit: if possible, longer and wider than the unit by at least 30 cm and 15/20cm higher than the surrounding surface
- it must be able to bear at least 4 times the operating weight of the unit
- it must allow level installation of the unit: although the unit is installed on a horizontal base, make slopes in the support surface to convey rain water or defrost water to drains, wells or in any case to places where it cannot generate an accident hazard due to ice formation. All heat pump version units are equipped with discharge manifolds for the condensed water; these can be manifolded to facilitate condensate discharge.

The units are designed and built to reduce to a minimum the level of vibration transmitted to the ground, but it is in any case advisable to use rubber or spring anti-vibration mounts, which are available as accessory and should be requested when ordering.

The anti-vibration mounts must be fixed on before positioning the unit on the ground.

In the event of installation on roofs or intermediate floors, the pipes must be isolated from the walls and ceilings.

It is advisable to avoid installation in cramped places, to prevent reverberations, reflections, resonances and acoustic interactions with elements outside the unit.

It is essential that any work done to soundproof the unit does not affect its correct installation or correct operation and, in particular, does not reduce the air flow rate to the source-side exchanger.

Installations that require the use of treated coils

If the unit has to be installed in an environment with a particularly aggressive atmosphere, coils with special treatments are available as options.

- coils with anti-corrosion treatment

A description of the individual accessories is available in the "Description of accessories" section.

The type of coil treatment should be chosen with regard to the environment in which the unit is to be installed, through observation of other structures and machinery with exposed metal surfaces present in the destination environment.

The cross observation criterion is the most valid method of selection currently available without having to carry out preliminary tests or measurements with instruments. The identified reference environments are:

- coastal/marine
- industrial
- urban with a high housing density
- rural

Please note that in cases where different conditions co-exist, even for short periods, the choice must be suitable for preserving the exchanger in the harsher environmental conditions and not in conditions between the worst and best situation.

Particular attention must be given in cases where an environment that is not particularly aggressive becomes aggressive as a consequence of a concomitant cause, for example, the presence of a flue outlet or an extraction fan.

We strongly suggest choosing one of the treatment options if at least one of the points listed below is verified:

- there are obvious signs of corrosion of the exposed metal surfaces in the installation area
- the prevailing winds come from the sea towards the unit
- the environment is industrial with a significant concentration of pollutants
- the environment is urban with a high population density
- the environment is rural with the presence of organic discharges and effluents

In particular, for installations near the coast, the following instructions apply:

- For units to be installed between 1 and 20 km from the coast, the use of the option "Coil treated with anti-corrosion paints" is strongly recommended.
- For units to be installed within one kilometre from the coast, the use of the option "Coil treated with anti-corrosion paints" is strongly recommended.

To protect the exchangers from corrosion and ensure optimal operation of the unit, we advise following the recommendations given in the user, installation and maintenance manual for cleaning the coils.

Aeraulic head losses and options available for the ventilating section

With the exception of units for which oversize fans are required, as standard, the units are designed considering that, at the nominal air flow rate, the fans work with null available pressure.

If there are obstacles to free air flow, you should consider the additional aeraulic head losses that will cause a reduction of the air flow rate and a consequent deterioration of performance.

The following diagrams show the trend of cooling capacity (PC), EER, total absorbed power (Pabs) and reduction of the maximum external air temperature in chiller operating mode, depending on the aeraulic head losses that the fans will have to overcome.

AC fans (Ø 630)

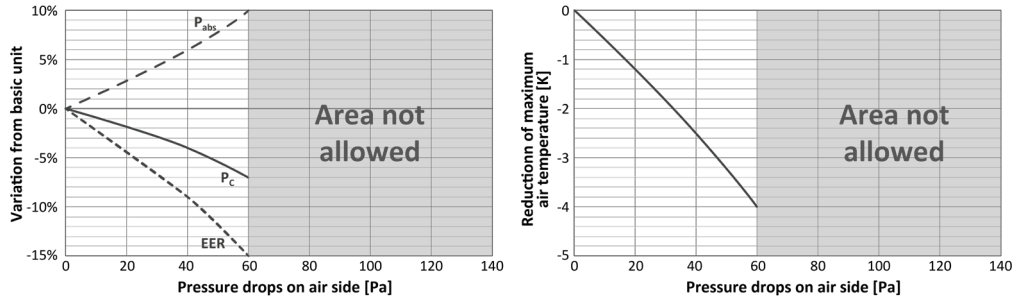

EC fans (Ø 630)

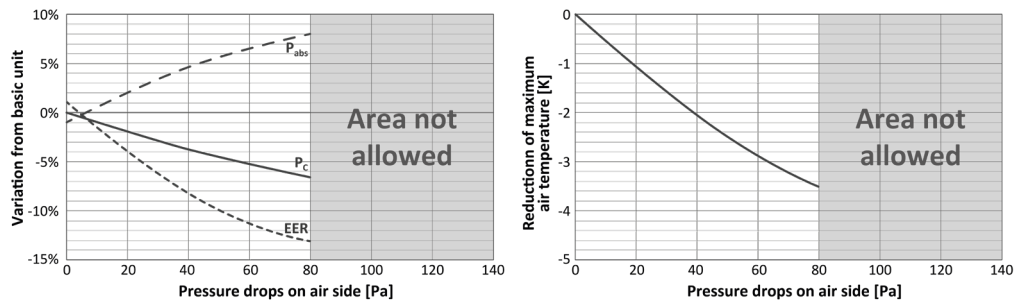

Oversize EC fans (Ø 630)

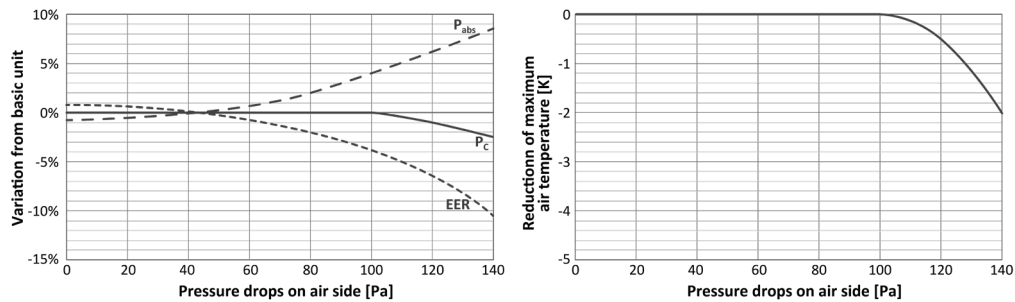

AC fans (Ø 800)

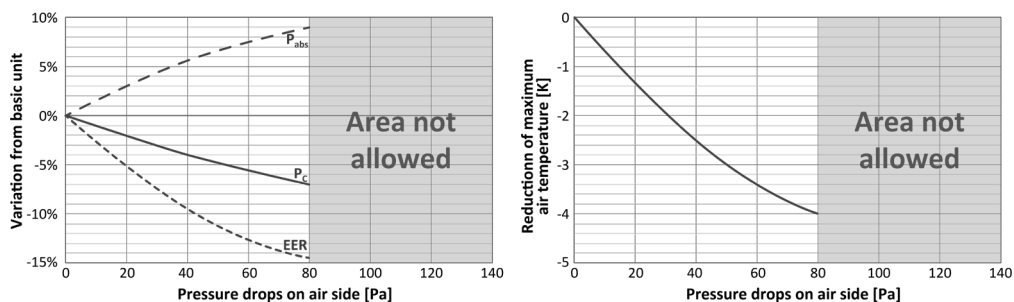

EC fans (Ø 800)

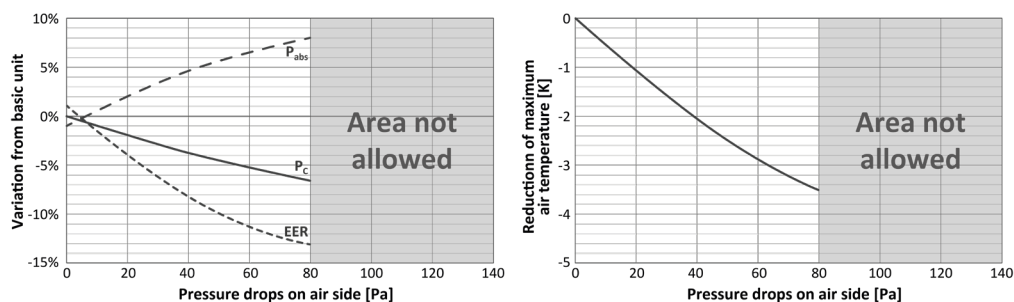

Oversize EC fans (Ø 800)

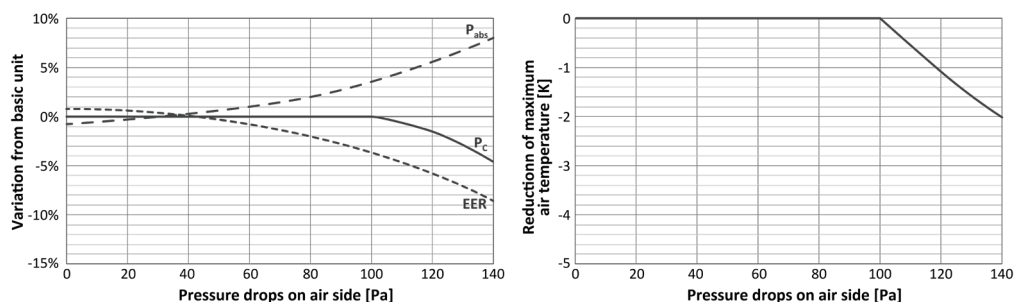

The indicated values are for the standard machine, without accessories, with AC fans and in any case in the absence of air recirculation.

Example: supposing you expect there to be obstacles that will generate an estimated aeraulic head loss of 60Pa. In this case, there are 3 possibilities:

- use the unit with standard AC fans: compared to ideal conditions, the output power will be reduced by about 5.5%, the total absorbed power will increase by about 7.5%, the EER will be reduced by about 12.5% and the maximum allowed external air temperature for operation at 100% will be reduced by about 3.4K compared to the nominal limit
- use the unit with EC fans: compared to the unit with AC fans working in ideal conditions, the output power will be reduced by about 5%, the total absorbed power will increase by about 6.5%, the EER will be reduced by about 11.5% and the maximum allowed external air temperature for operation at 100% will be reduced by about 2.8K compared to the nominal limit
- use the unit with oversize EC fans: compared to the unit with AC fans working in ideal conditions, the output power of the unit will be unchanged, the total absorbed power will increase by about 1%, the EER will be reduced by about 2% and the maximum external air temperature will remain the one shown in the diagram of the operating limits.

It is emphasized that, as indicated in the diagrams and based on the diameter and type of fan, for aeraulic head losses higher than 60 or 80Pa, only the use of oversize EC fan is allowed.

DIMENSIONAL DIAGRAMS

ZETA REV HP XT 3.2 (ST)-1P-2P

DDIM000043B

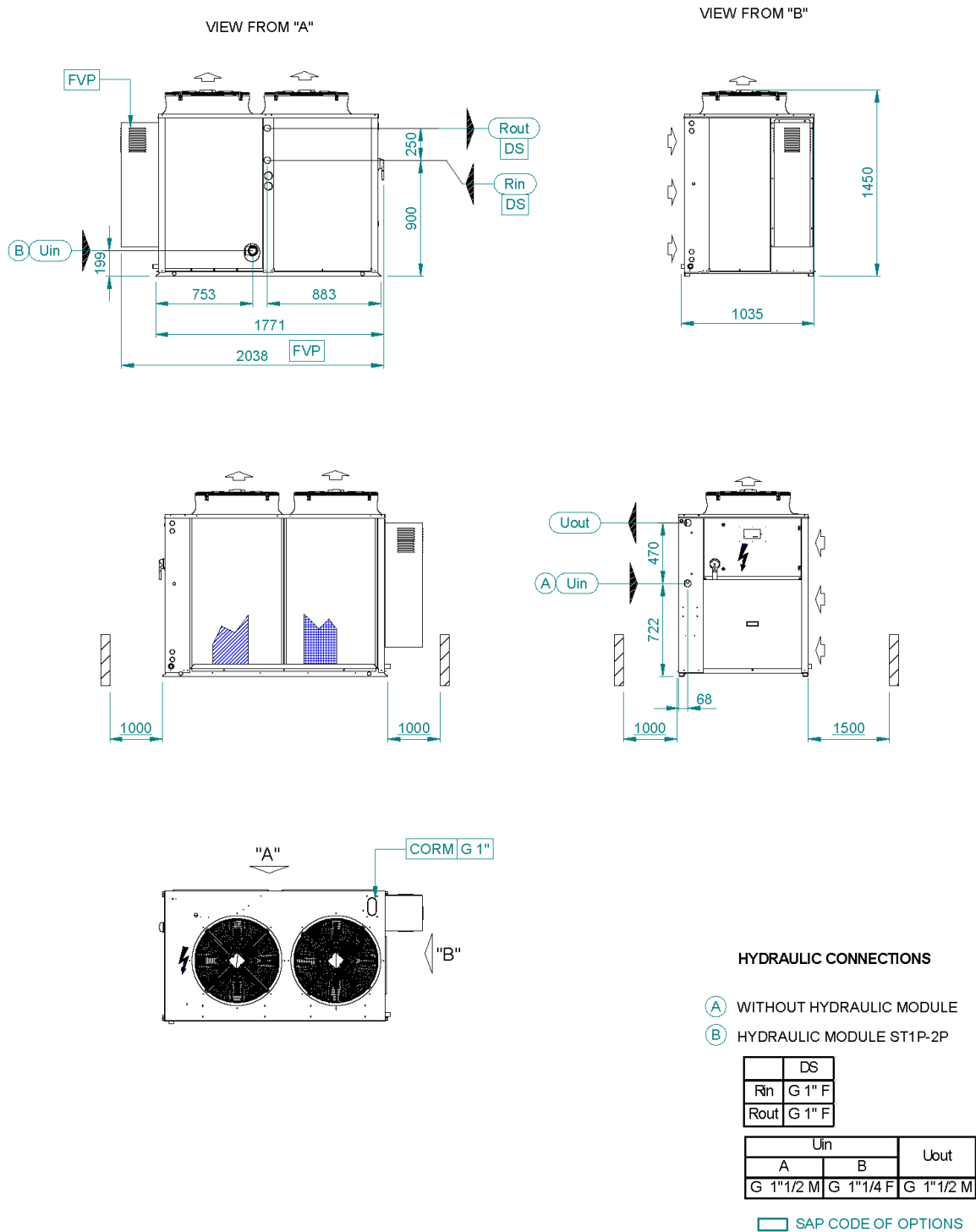

Note: These drawings are not contractually binding. For the installation design, refer to the specific dimensional drawing available on request.

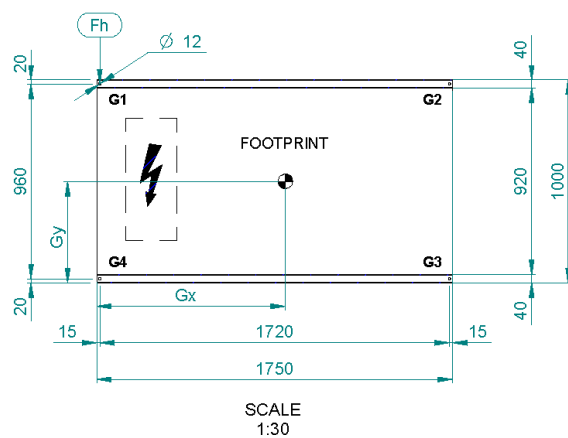

MODEL	WEIGHT(kg)	OPERATING WEIGHT(kg)	G1 (kg)	G2 (kg)	G3 (kg)	G4 (kg)	XG	YG
ZETA REV HP XT 3.2 HP	464	467	164	81	73	149	583	523
ZETA REV HP XT 3.2 HP 1P-2P	509	512	173	99	87	153	643	528
ZETA REV HP XT 3.2 HP_DS	467	471	167	83	73	148	585	527
ZETA REV HP XT 3.2 HP 1P-2P_DS	513	517	175	101	88	153	645	531

Note: These drawings are not contractually binding. For the installation design, refer to the specific dimensional drawing available on request.

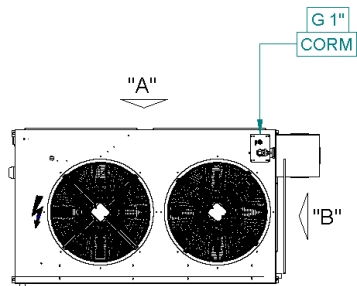
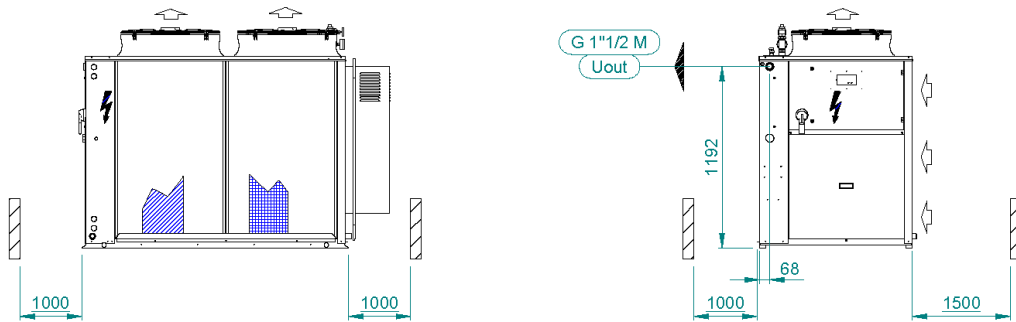
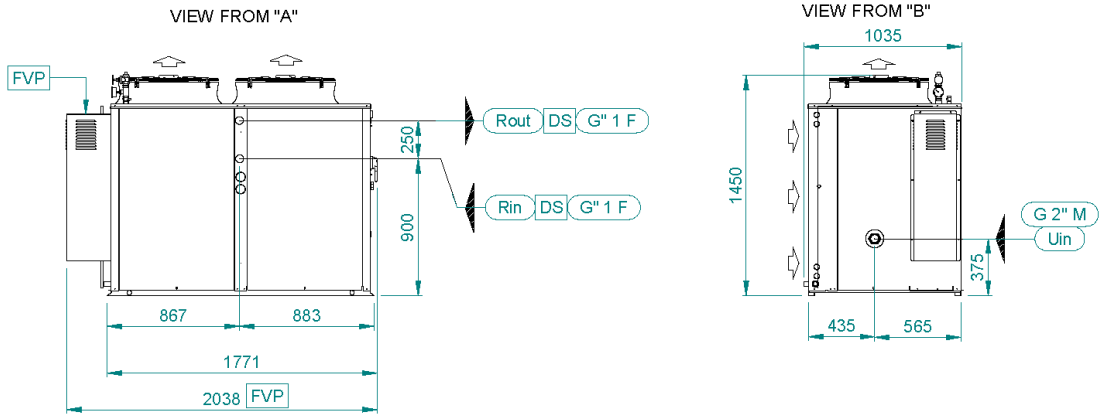

SAP CODE OF OPTIONS

Note: These drawings are not contractually binding. For the installation design, refer to the specific dimensional drawing available on request.

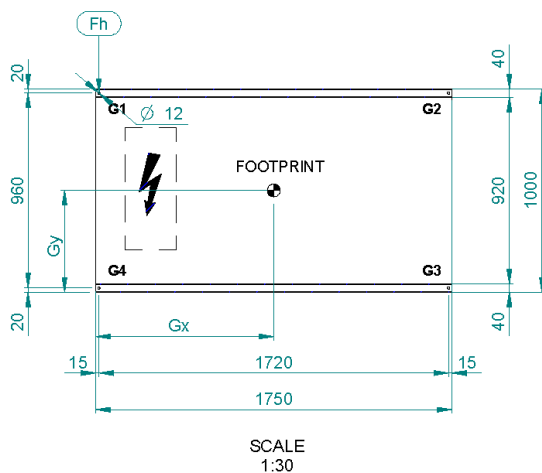

MODEL	WEIGHT(kg)	OPERATING WEIGHT (kg)	G1 (kg)	G2 (kg)	G3 (kg)	G4 (kg)	Gx	Gy
ZETA REV HP XT 3.2 HP_1PS-2PS	605	778	199	187	190	202	747	541
ZETA REV HP XT 3.2 HP_1PS-2PS_DS	612	786	202	190	191	203	747	545

Note: These drawings are not contractually binding. For the installation design, refer to the specific dimensional drawing available on request.

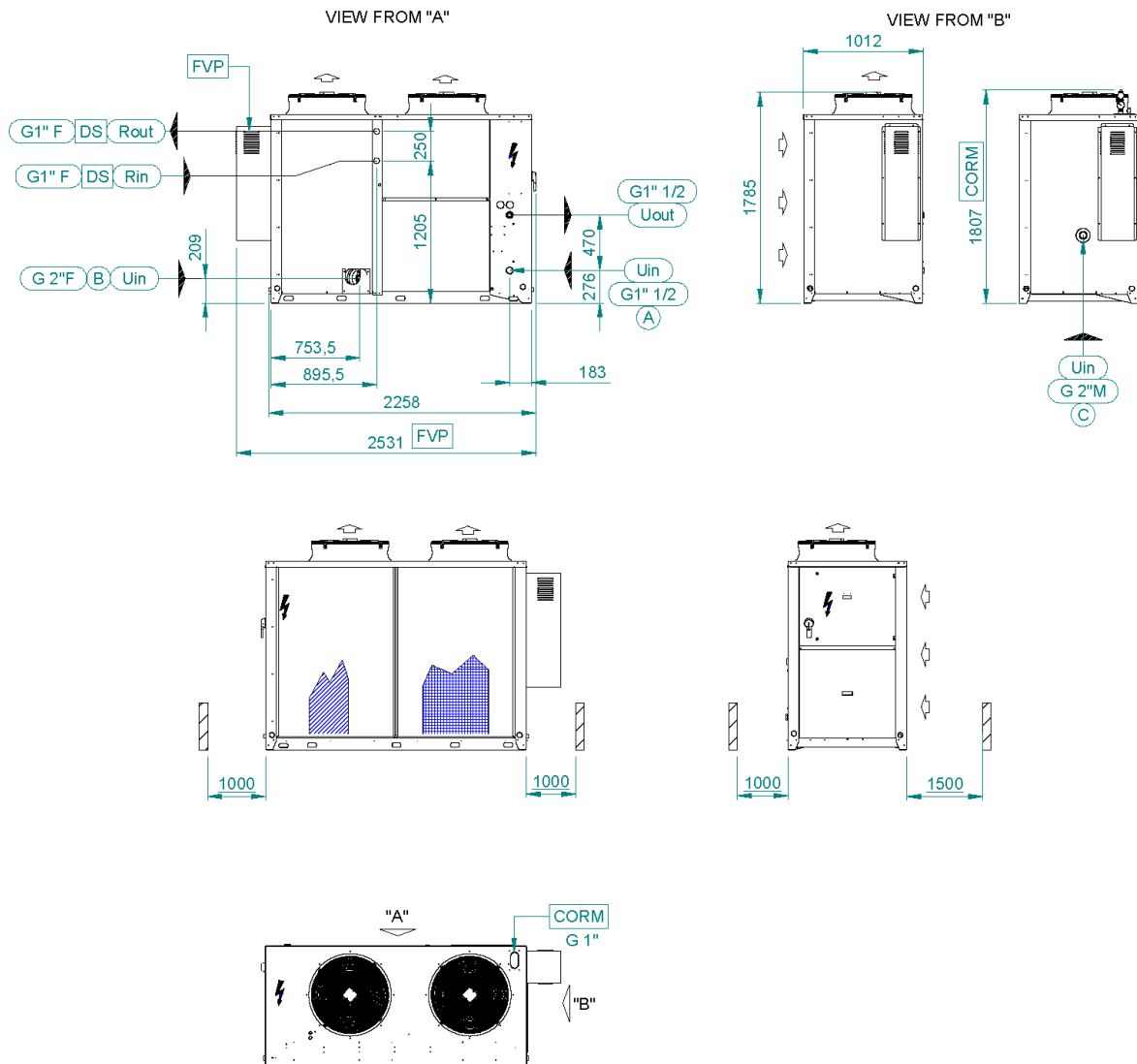

HYDRAULIC CONNECTIONS

- (A) WITHOUT HYDRAULIC MODULE
- (B) HYDRAULIC MODULE ST1P-2P
- (C) HYDRAULIC MODULE ST1PS

SAP CODE OF OPTIONS

Note: These drawings are not contractually binding. For the installation design, refer to the specific dimensional drawing available on request.

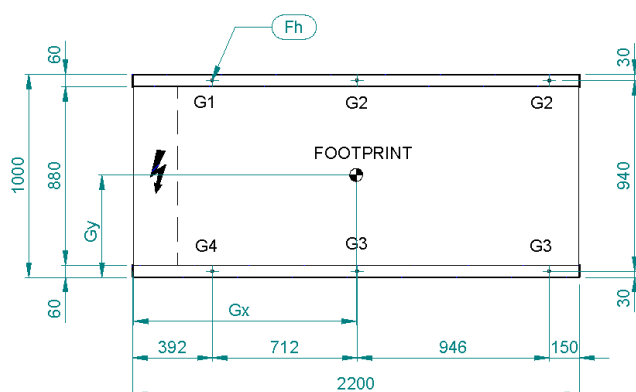

MODEL	WEIGHT(kg)	OPERATING WEIGHT (kg)	G1 (kg)	G2 (kg)	G3 (kg)	G4 (kg)	Gx	Gy
ZETA REV HP XT 4.2	639	643	209	68	59	180	864	548
ZETA REV HP XT 4.2 HP 1P-2P	642	652	179	82	74	161	956	536
ZETA REV HP XT 4.2 HP 1PS	736	930	173	149	131	152	981	547
ZETA REV HP XT 4.2 HP_DS	671	675	219	76	62	180	880	560
ZETA REV HP XT 4.2 HP 1P-2P_DS	731	741	215	97	79	174	952	564
ZETA REV HP XT 4.2 HP 1PS_DS	767	961	181	157	134	154	991	556
ZETA REV HP XT 5.2 HP	649	655	216	69	59	183	860	552
ZETA REV HP XT 5.2 HP 1P-2P	710	722	213	91	75	177	936	557
ZETA REV HP XT 5.2 HP 1PS	744	940	177	149	129	154	977	550
ZETA REV HP XT 5.2 HP_DS	680	686	225	77	62	183	877	563
ZETA REV HP XT 5.2 HP 1P-2P_DS	739	751	222	98	78	177	948	566
ZETA REV HP XT 5.2 HP 1PS_DS	775	971	185	157	132	156	987	559

Note: These drawings are not contractually binding. For the installation design, refer to the specific dimensional drawing available on request.

VIEW FROM "A"

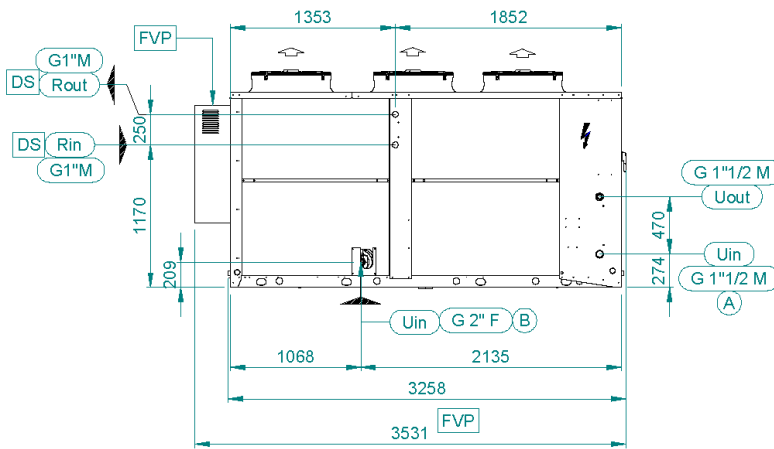

VIEW FROM "B"

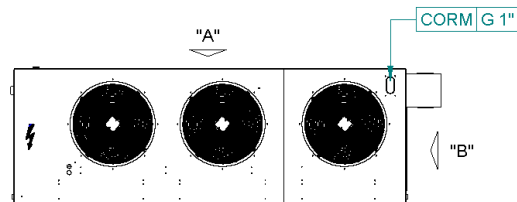
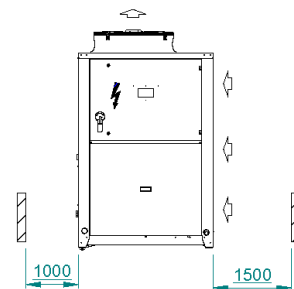
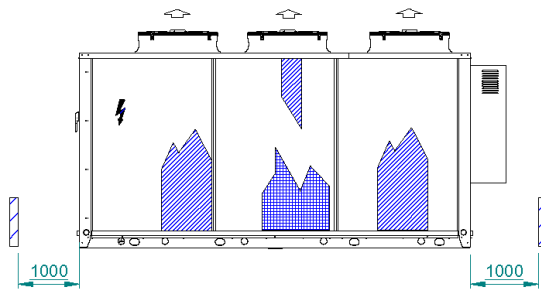
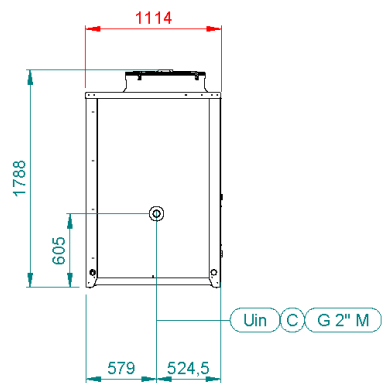

HYDRAULIC CONNECTIONS

- (A) WITHOUT HYDRAULIC MODULE
- (B) HYDRAULIC MODULE ST1P-2P
- (C) HYDRAULIC MODULE ST1PS-2PS

SAP CODE OF OPTIONS

Note: These drawings are not contractually binding. For the installation design, refer to the specific dimensional drawing available on request.

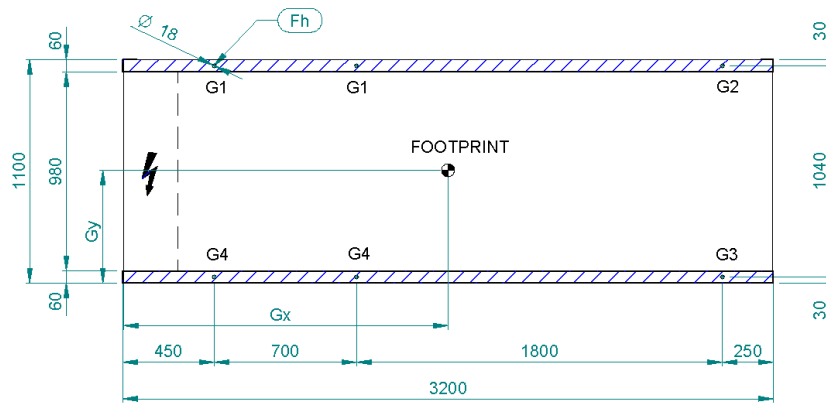

MODEL	WEIGHT(kg)	OPERATING WEIGHT (kg)	G1 (kg)	G2 (kg)	G3 (kg)	G4 (kg)	Gx	Gy
ZETA REV HP XT 6.2	721	725	160	64	57	142	964	542
ZETA REV HP XT 6.2 1P-2P	768	777	161	95	82	139	1088	548
ZETA REV HP XT 6.2 1PS-2PS	871	1315	188	340	285	157	1219	548
ZETA REV HP XT 6.2_DS	726	731	162	67	58	141	971	546
ZETA REV HP XT 6.2 1P-2P_DS	785	795	165	97	84	142	1084	548
ZETA REV HP XT 6.2 1PS-2PS_DS	876	1321	189	344	285	157	1223	551
ZETA REV HP XT 7.2	731	735	163	65	58	143	964	543
ZETA REV HP XT 7.2 1P-2P	791	800	166	95	83	145	1076	545
ZETA REV HP XT 7.2 1PS-2PS	881	1325	190	342	285	159	1215	548
ZETA REV HP XT 7.2_DS	738	743	165	68	59	143	971	547
ZETA REV HP XT 7.2 1P-2P_DS	796	806	168	98	84	144	1081	549
ZETA REV HP XT 7.2 1PS-2PS_DS_LN	887	1332	192	345	285	159	1219	552

Note: These drawings are not contractually binding. For the installation design, refer to the specific dimensional drawing available on request.

VIEW FROM "A"

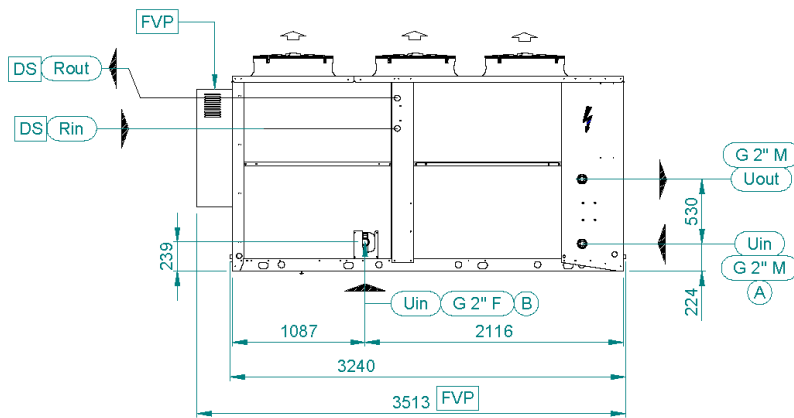

VIEW FROM "B"

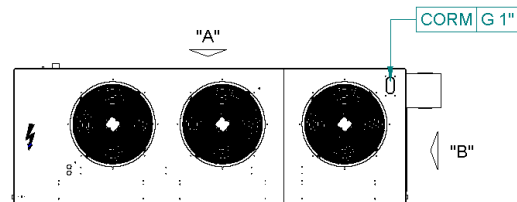
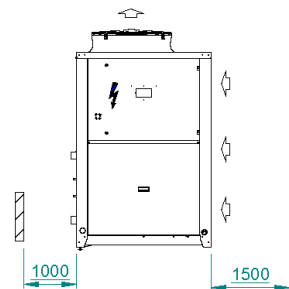
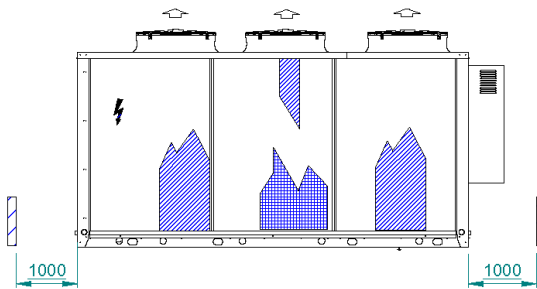
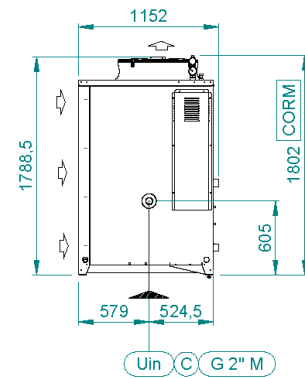

HYDRAULIC CONNECTIONS

- (A) WITHOUT HYDRAULIC MODULE
- (B) HYDRAULIC MODULE ST1P-2P
- (C) HYDRAULIC MODULE ST1PS-2PS

SAP CODE OF OPTIONS

Note: These drawings are not contractually binding. For the installation design, refer to the specific dimensional drawing available on request.

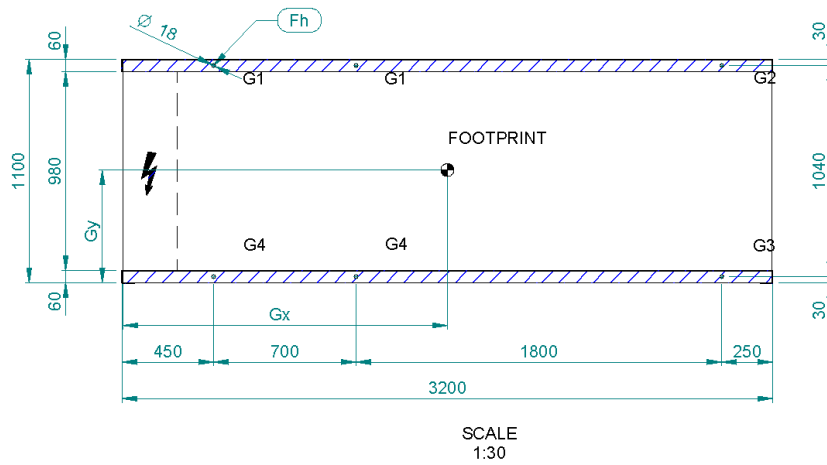

MODEL	WEIGHT(kg)	OPERATING WEIGHT (kg)	G1 (kg)	G2 (kg)	G3 (kg)	G4 (kg)	Gx	Gy
ZETA REV HP XT 8.2	859	865	177	92	87	166	1252	579
ZETA REV HP XT 8.2 1P-2P	940	956	183	126	118	173	1345	579
ZETA REV HP XT 8.2 1PS-2PS	1010	1466	213	326	310	202	1428	578
ZETA REV HP XT 8.2_DS	869	876	180	96	88	166	1257	583
ZETA REV HP XT 8.2 1P-2P_DS	950	967	186	129	120	173	1349	582
ZETA REV HP XT 8.2 1PS-2PS_DS	1017	1474	215	330	310	202	1431	582

Note: These drawings are not contractually binding. For the installation design, refer to the specific dimensional drawing available on request.

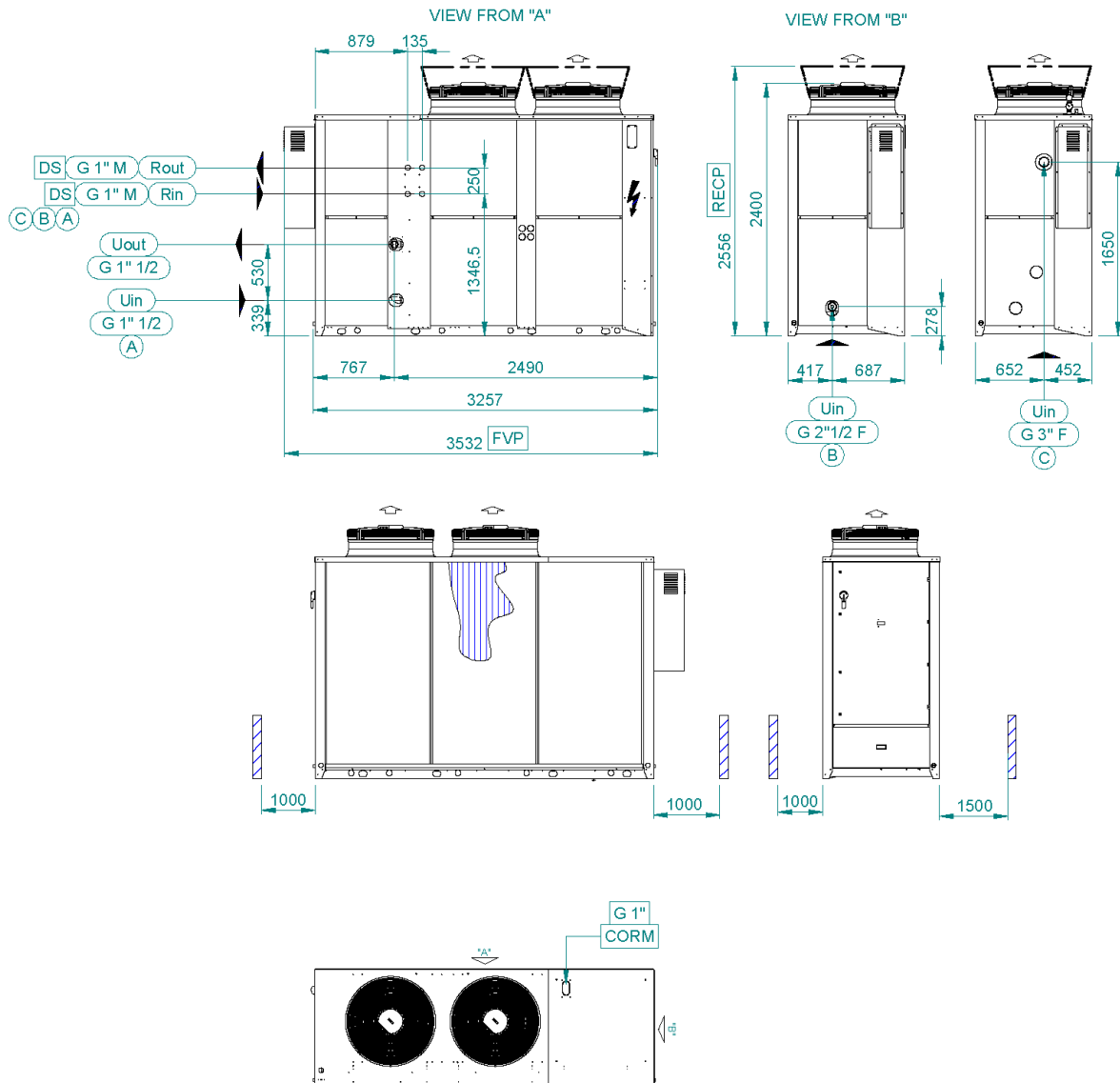

HYDRAULIC CONNECTIONS

- (A) WITHOUT HYDRAULIC MODULE
- (B) HYDRAULIC MODULE ST1P-2P
- (C) HYDRAULIC MODULE ST1PS-2PS

□ SAP CODE OF OPTIONS

Note: These drawings are not contractually binding. For the installation design, refer to the specific dimensional drawing available on request.

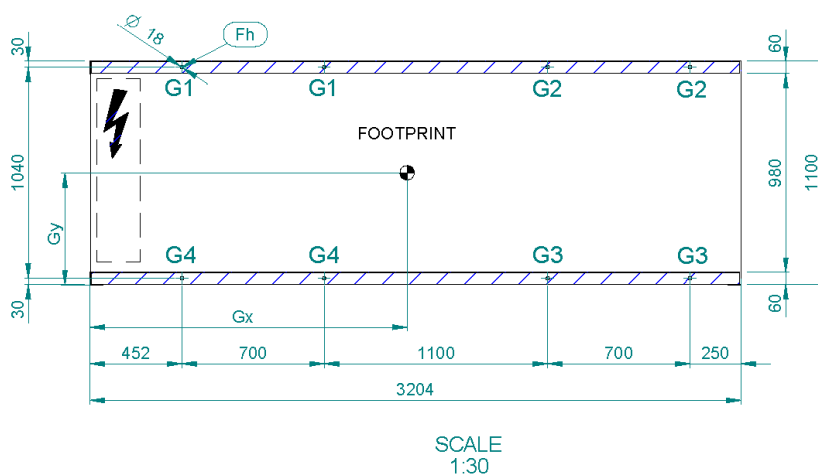

MODEL	WEIGHT(kg)	OPERATING WEIGHT(kg)	G1 (kg)	G2 (kg)	G3 (kg)	G4 (kg)	GX	GY
ZETA REV HP XT 9.2 HP	1174	1186	222	93	82	196	1322	590
ZETA REV HP XT 9.2 HP_1P-2P	1254	1276	223	122	104	189	1419	599
ZETA REV HP XT 9.2 HP_1PS-2PS	1378	1780	210	279	229	172	1541	599
ZETA REV HP XT 9.2_DS	1198	1214	228	100	85	194	1339	598
ZETA REV HP XT 9.2 HP_1P-2P_DS	1278	1304	228	130	107	187	1433	607
ZETA REV HP XT 9.2 HP_1PS-2PS_DS	1396	1802	213	287	230	171	1552	606

Note: These drawings are not contractually binding. For the installation design, refer to the specific dimensional drawing available on request.

VIEW FROM "A"

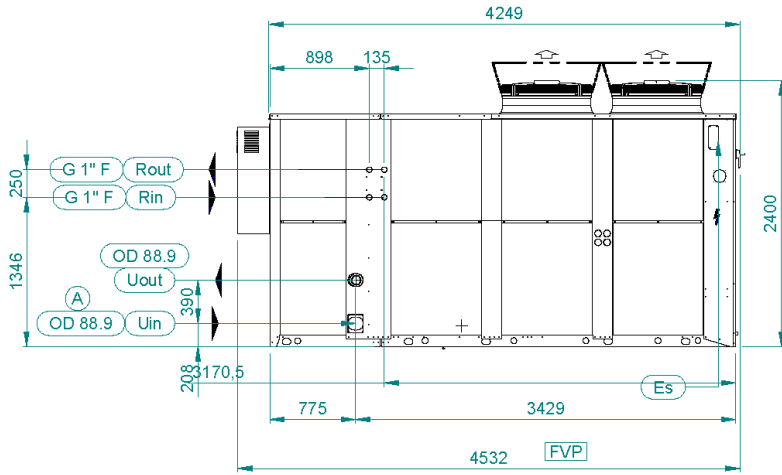

VISTA DA "B"

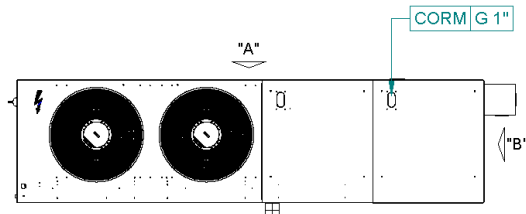
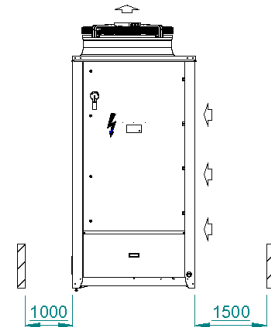
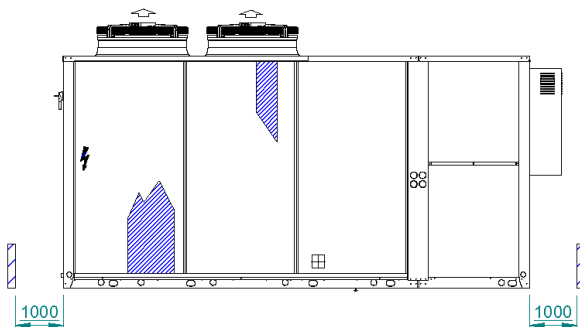
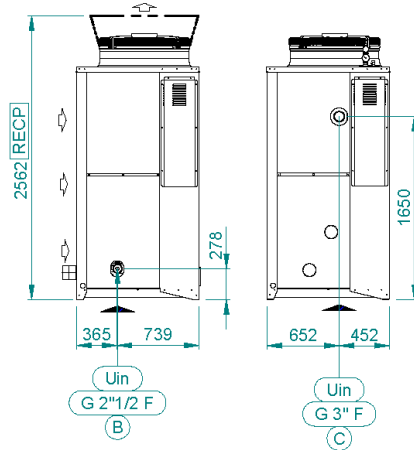

HYDRAULIC CONNECTIONS

- (A) WITHOUT HYDRAULIC MODULE
- (B) HYDRAULIC MODULE ST1P-2P
- (C) HYDRAULIC MODULE ST1PS-2PS

 SAP CODE OF OPTIONS

Note: These drawings are not contractually binding. For the installation design, refer to the specific dimensional drawing available on request.

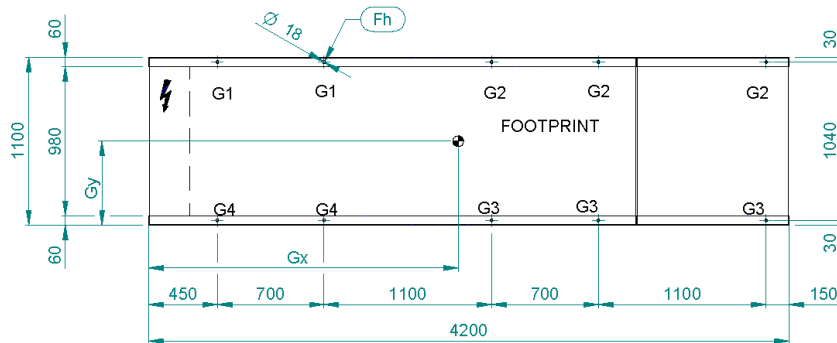

SCALE
1:40

MODEL	WEIGHT(kg)	OPERATING WEIGHT (kg)	G1 (kg)	G2 (kg)	G3 (kg)	G4 (kg)	XG	XY
ZETA REV HP XT 10.4 HP	1615	1625	242	129	112	209	1807	598
ZETA REV HP XT 10.4 HP_1P-2P	1698	1708	236	150	128	201	1908	602
ZETA REV HP XT 10.4 HP_DS	1636	1656	245	137	115	205	1825	603
ZETA REV HP XT 10.4 HP_1P-2P_DS	1717	1737	238	158	131	197	1924	607

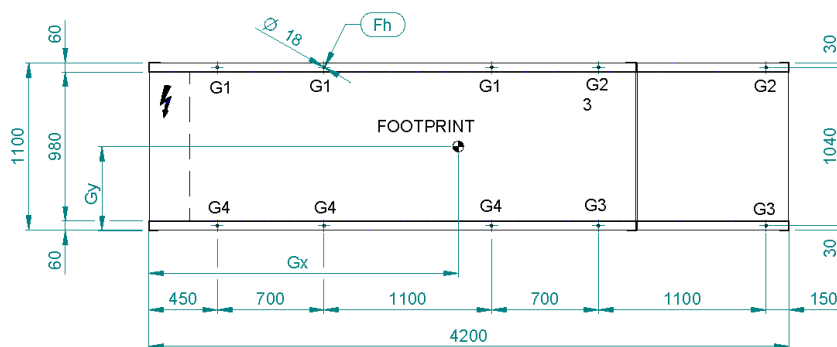

SCALE
1:40

MODEL	WEIGHT(kg)	OPERATING WEIGHT (kg)	G1 (kg)	G2 (kg)	G3 (kg)	G4 (kg)	XG	XY
ZETA REV HP XT 10.4 HP_1PS-2PS	2204	2214	213	298	236	169	2350	621
ZETA REV HP XT 10.4 HP_1PS-2PS_DS	2223	2243	216	308	239	167	2358	624

Note: These drawings are not contractually binding. For the installation design, refer to the specific dimensional drawing available on request.

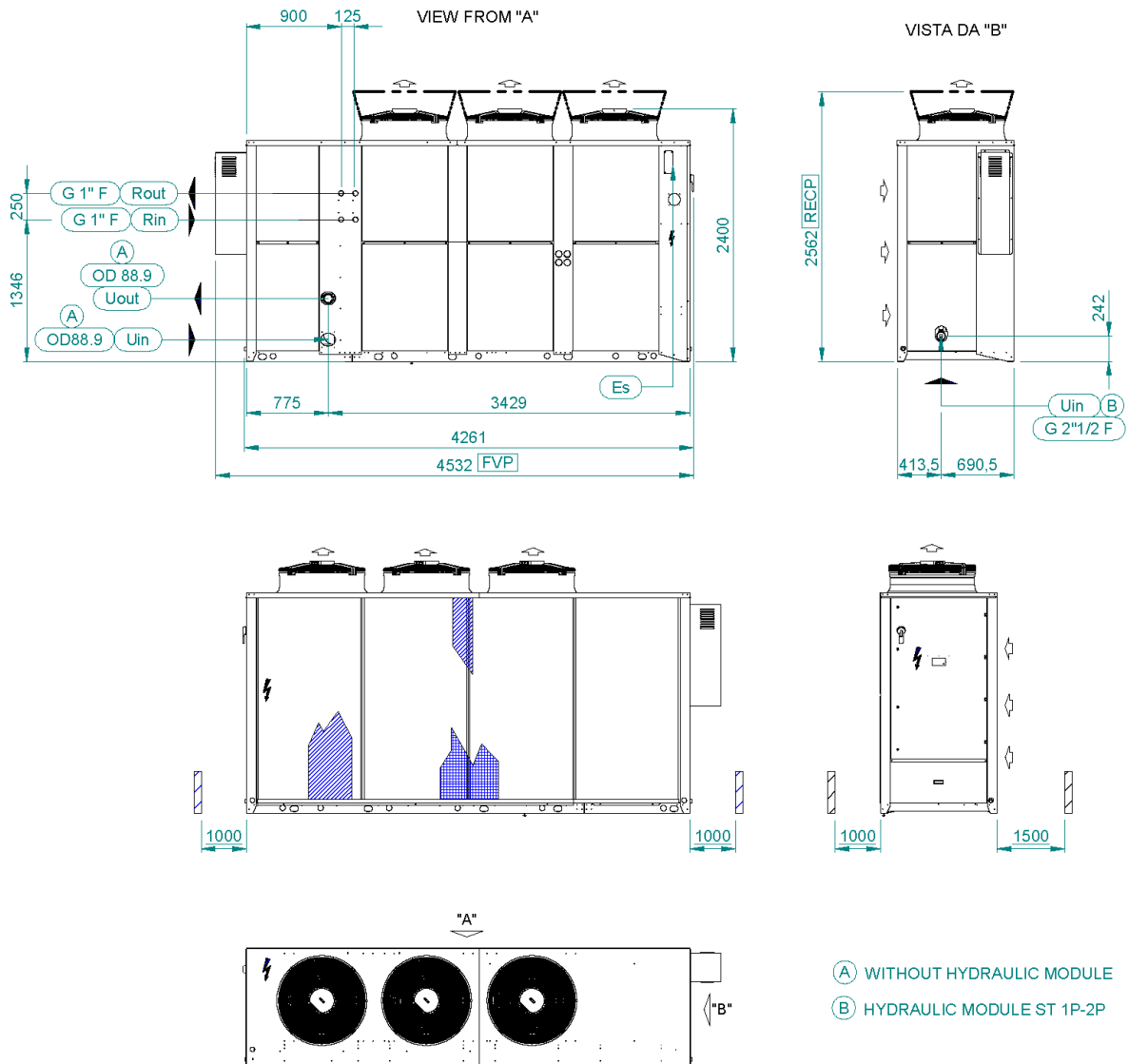

- (A) WITHOUT HYDRAULIC MODULE
- (B) HYDRAULIC MODULE ST 1P-2P

SAP CODE OF OPTIONS

Note: These drawings are not contractually binding. For the installation design, refer to the specific dimensional drawing available on request.

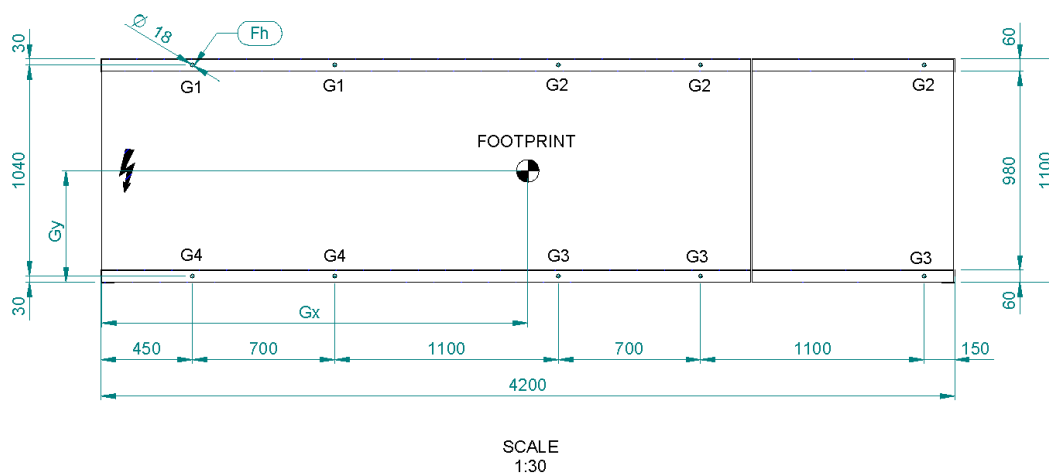

MODEL	WEIGHT(kg)	OPERATING WEIGHT (kg)	G1 (kg)	G2 (kg)	G3 (kg)	G4 (kg)	Gx	Gy
ZETA REV HP XT 12.4	1743	1753	273	117	112	260	1684	572
ZETA REV HP XT 12.4_DS	1761	1776	275	123	115	256	1702	576
ZETA REV HP XT 12.4_1P-2P	1893	1918	261	156	146	245	1855	575
ZETA REV HP XT 12.4_1P-2P_DS	1913	1943	263	162	149	242	1870	580
ZETA REV HP XT 14.4	1780	1790	278	121	115	263	1693	573
ZETA REV HP XT 14.4_DS	1801	1818	281	128	118	259	1714	579
ZETA REV HP XT 14.4_1P-2P	1928	1953	265	160	149	248	1860	577
ZETA REV HP XT 14.4_1P-2P_DS	1952	1984	268	167	153	244	1878	582

Note: These drawings are not contractually binding. For the installation design, refer to the specific dimensional drawing available on request.

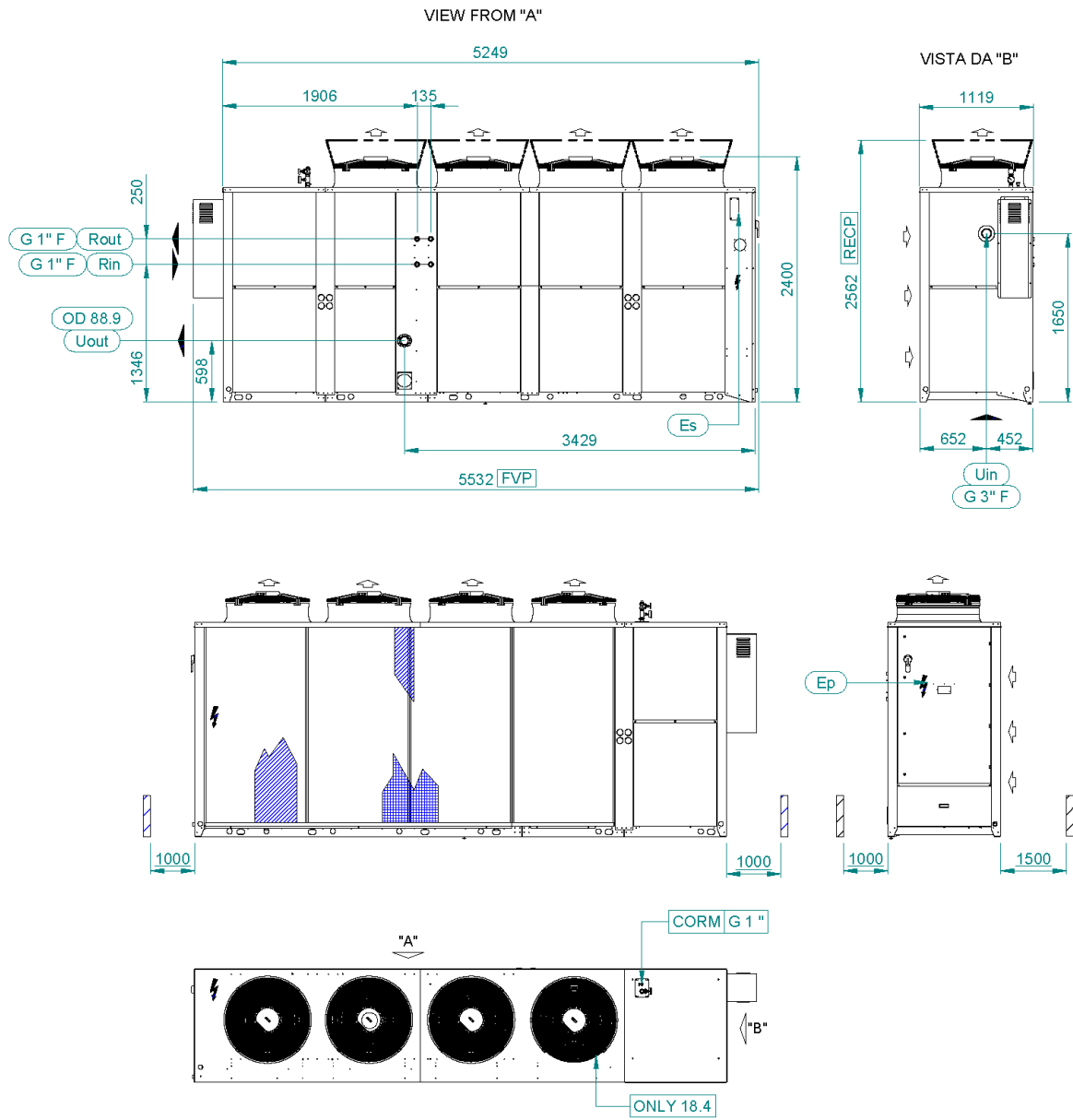

Note: These drawings are not contractually binding. For the installation design, refer to the specific dimensional drawing available on request.

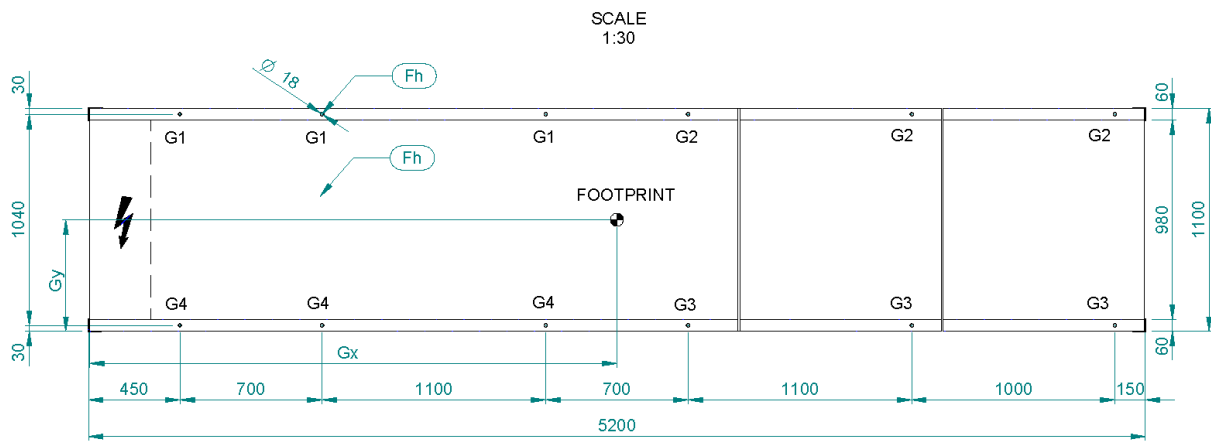

MODEL	WEIGHT(kg)	OPERATING WEIGHT (kg)	G1 (kg)	G2 (kg)	G3 (kg)	G4 (kg)	Gx	Gy
ZETA REV HP XT 12.4 1PS-2PS	2075	2805	224	282	239	190	2151	586
ZETA REV HP XT 14.4 1PS-2PS	2082	2817	225	284	240	190	2156	587
ZETA REV HP XT 16.4 1PS-2PS	2112	2847	229	286	241	193	2155	587
ZETA REV HP XT 18.4 1PS-2PS	2131	2871	232	288	242	195	2154	588
ZETA REV HP XT 12.4 1PS-2PS_DS	2090	2823	226	286	240	189	2161	590
ZETA REV HP XT 14.4 1PS-2PS_DS	2103	2841	228	289	241	189	2167	591
ZETA REV HP XT 16.4 1PS-2PS_DS	2135	2874	232	291	242	193	2167	592
ZETA REV HP XT 18.4 1PS-2PS_DS	2154	2898	235	294	243	194	2167	593

Note: These drawings are not contractually binding. For the installation design, refer to the specific dimensional drawing available on request.

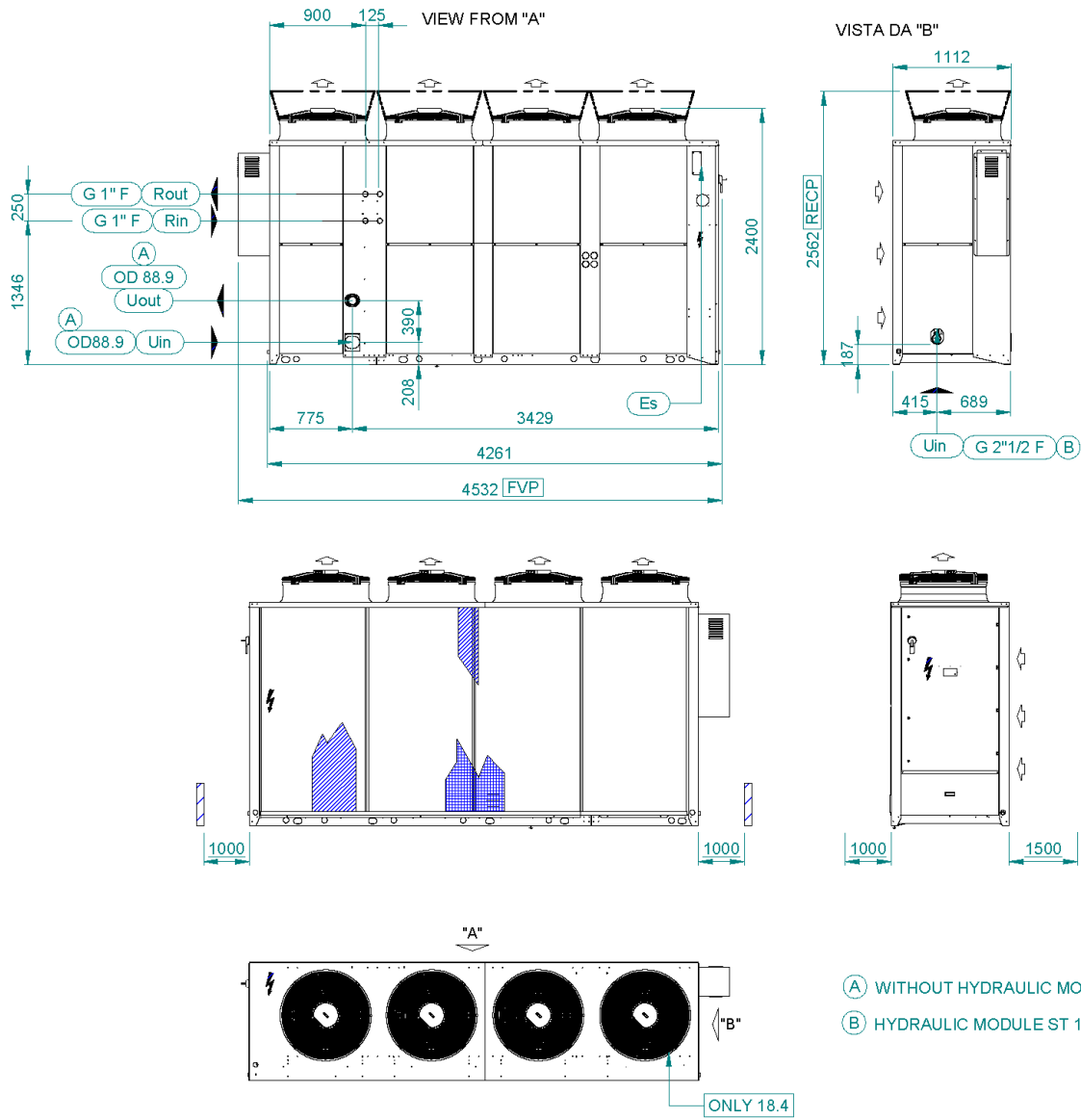

- (A) WITHOUT HYDRAULIC MODULE
- (B) HYDRAULIC MODULE ST 1P-2P

Note: These drawings are not contractually binding. For the installation design, refer to the specific dimensional drawing available on request.

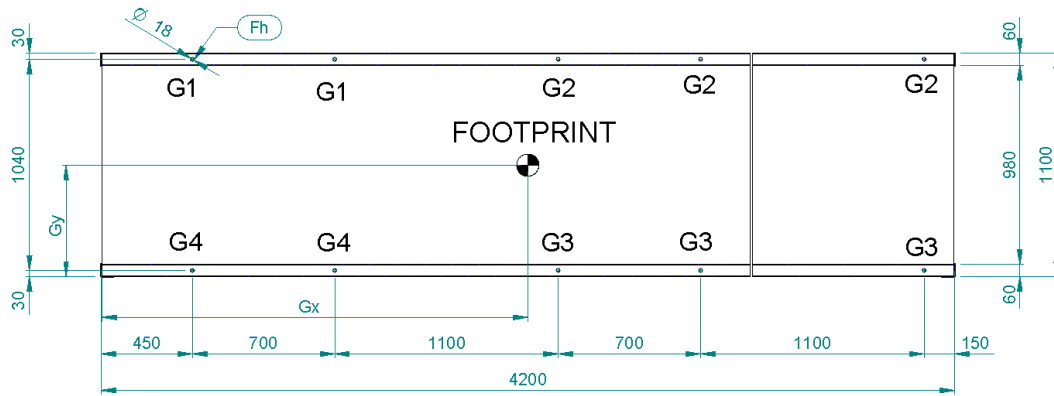

SCALE
1:30

MODEL	WEIGHT(kg)	OPERATING WEIGHT (kg)	G1 (kg)	G2 (kg)	G3 (kg)	G4 (kg)	Gx	Gy
ZETA REV HP XT 16.4 HP	1772	1787	288	146	111	220	1773	630
ZETA REV HP XT 16.4 HP 1P-2P	1799	1829	260	167	132	206	1894	621
ZETA REV HP XT 18.4 HP	1793	1808	292	148	112	222	1773	631
ZETA REV HP XT 18.4 1P-2P	1919	1949	278	183	140	212	1910	631
ZETA REV HP XT 16.4 HP_DS	1824	1845	295	157	116	218	1798	637
ZETA REV HP XT 16.4 HP 1P-2P_DS	1948	1984	280	193	143	208	1932	636
ZETA REV HP XT 18.4 HP_DS	1829	1852	295	159	117	217	1803	638
ZETA REV HP XT 18.4 1P-2P_DS	1955	1993	281	195	144	207	1936	637

Note: These drawings are not contractually binding. For the installation design, refer to the specific dimensional drawing available on request.

